

Anko

K: 43461509 | T: 70125627 (Model: JLR-79862)

Wireless kitty headphones

Operating instructions

Includes:

- Headset
- Manual
- USB charging cable
- 3.5mm aux in cable

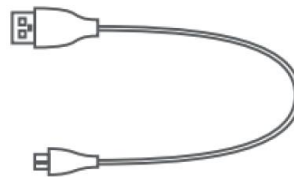

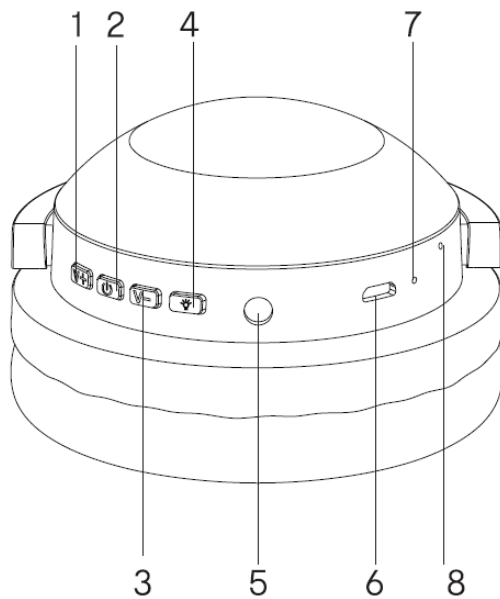

1. Short press to Volume+. Long press to next song
2. **Power button and play/pause**
3. Short press to Volume-. Long press to previous song
4. Led light
5. 3.5mm audio input line/Auxiliary
6. Micro USB Charging Port
7. Indicator light
8. Microphone

How to use this headphone

1. Power on/off
 Long press 2) button 3 seconds to turn the unit on
 Long press 2) button 3 seconds to turn the unit off
2. **play/pause**
 - 1) **Turn the unit on**
 - 2) **Short press power button to play/pause music**
3. Pairing a Bluetooth device for the first time
 - 1) Turn the unit on.
 - 2) Turn on your external device.
 - 3) Select Bluetooth device name “anko43461509” your Bluetooth settings menu to pair.
 - 4) When successfully paired and connected. a beep will issue from the unit.
 - 5) After initial pairing, the unit will stay paired unless unpaired manually by the user.
 - 6) If you have used Bluetooth connection before, the system will start searching for the device last connected. When the device is found, the system will re-connect automatically.

NOTE:

- 1) Only one Bluetooth device can be connected to the headphone at one time. When Aux in is connected, Bluetooth function will be switched off, please disconnect the Aux in cable before using Bluetooth.
- 2) Should your device become unpaired or you are not able to connect it, repeat the above steps.

4. Charging

The headphone is powered via an integrated rechargeable battery. The battery cannot be removed or replaced.

Upon initial use, the battery should be charged fully to ensure optimal performance and battery life.

Charge the device with the included USB charging cable. Plug the micro-USB end of the charging cable into the DC charging port and the USB-A into a suitable USB port on your computer or a USB wall charger with DC5V.

The indicator light will turn red and **device will turn off while charging**. Once fully charged, the red light will turn **blue**. Charging time approx. 3-4 hours.

Wired mode:

Plug the 3.5mm cable into the AUX port, connect the other end with mobile phone, computer or other audio equipment. The headphone can be used as wired headphone without starting.

Note:

- 1) In this mode, you can't use any function of the headphone, including pause playback, volume adjustment and soon on.
- 2) The headphone will automatically switch off and become a wired headphone after plugging in the 3.5mm audio cable.

Led light

- 1) Turn on the device, led light will turn on automatically
- 2) Press the light button once to switch the color (color: green -blue-red-light blue-yellow-pink-white)
- 3) Click twice, switch to ambient light, then light change automatically.
- 4) Long press light button to turn off

Hands free

Short Press 2) button to answer or hang up a phone call

Long press 2) button to reject call

Specifications:

Bluetooth version: 5.3

DRIVER: 40mm

IMPEDANCE: 32Ohm

Sensitivity: 112±3dB
Build-in Rechargeable battery
Charging time up to 3-4 hours

12 Month Warranty

Thank you for your purchase.

Your new product is warranted to be free from defects in materials and workmanship for the period stated above, from the date of purchase, provided that the product is used in accordance with accompanying recommendations or instructions where provided. This warranty is in addition to your rights under the Australian Consumer Law.

For New Zealand customers, this warranty is in addition to statutory rights observed under New Zealand legislation.

We will provide you with your choice of a refund, repair (where possible) or exchange (availability dependent) for this product if it becomes defective within the warranty period. The business will bear the reasonable expense of claiming the warranty. This warranty will no longer apply where the defect is a result of alteration, accident, misuse, abuse or neglect.

Please retain your receipt as proof of purchase and contact our Customer Service Centre as listed below, for the entity you purchased this product from, for any difficulties with your product. Warranty claims and claims for expense incurred in returning this product can be addressed to the respective Customer Service Centre.

Our goods come with guarantees that cannot be excluded under the Australian Consumer Law. You are entitled to a replacement or refund for a major failure and compensation for any other reasonably foreseeable loss or damage.

You are also entitled to have the goods repaired or replaced if the goods fail to be of acceptable quality and the failure does not amount to a major failure.

Contact for Kmart purchases	Contact for Target purchases
Kmart Australia Ltd. C/- Customer Service Centre 690 Springvale Road, Mulgrave Vic 3170 Customer Service: 1800 124 125 (Australia) or 0800 945 995 (New Zealand) or via Customer Help at kmart.com.au	Target Australia Pty Ltd C/- Customer Service Centre 2 Kendall Street, Williams Landing, Vic, 3027 Customer Service: 1300 753 567 or via Customer Help at target.com.au/help/contact-us

