

# anko

## Ice Maker

**KICE669**

### **Instruction Manual**



To ensure proper operation of this device, please read this instruction manual carefully before using the device and keep it for further reference.

## IMPORTANT SAFEGUARDS

When using electrical appliances, in order to reduce the risk of fire, electric shock, and/or injury to persons, basic safety precautions should always be followed, including:

### FOR YOUR SAFETY

*Read all instructions carefully, even if you feel you are quite familiar with the appliance.*

- This appliance is not intended for use by persons (including children) with reduced physical, sensory and mental capabilities, or lack of experience and knowledge, unless they have been given supervision or instruction concerning use of the appliance by a person responsible for their safety.
- Children should be supervised to ensure that they do not play with the appliance.
- To protect against fire, electric shock or injury, do not immerse power cord, plug or main unit in water or other liquid.
- Do not allow the power cord to hang over the edge of a table or bench, touch hot surfaces or become knotted.
- Do not place this appliance on or near a gas burner or electric element, or where it could touch a heated oven.
- Do not operate any appliance with a damaged power cord or plug, if the appliance malfunctions, or if it has been damaged in any manner.
- This appliance is for household use only. Do not use this appliance for any purpose other than specified in this booklet. Indoor use only.
- Do not attempt to repair or disassemble the appliance. There are no user-serviceable parts.
- Ensure the voltage is compliant with the voltage range stated on the rating label, and ensure the earthing of the socket is in good condition.
- Do not connect the appliance to an electrical socket until all parts have been assembled according to the instructions.

- Operate on a dry level surface. Do not operate in sinks, on drainboards or uneven surfaces.
- After use or before moving, replacing parts, or cleaning the appliance, make sure the appliance is turned OFF and then switched OFF at the power outlet.
- Do not handle the appliance with wet hands or when standing on a damp surface while it is connected to a power source.
- The operating temperature of the appliance is between 5–35°C.
- Do not turn the appliance upside down or incline it beyond 45° angle. This can make the compressor or refrigeration system operate incorrectly.
- To avoid frostbite, do not touch the evaporator while making ice.
- Warning: Do not store explosive substances such as aerosol cans with a flammable propellant in this appliance.
- Warning: Keep ventilation openings, in the appliance enclosure or in the built-in structure, clear of obstruction.
- Warning: Do not use mechanical devices or other means to accelerate the defrosting process, other than those recommended by the manufacturer.
- Warning: Do not damage the refrigerant circuit.
- Warning: When positioning the appliance, ensure the supply cord is not trapped or damaged.
- Warning: Do not locate multiple power socket-outlets or portable power supplies at the rear of the appliance.
- Warning: The appliance should be disposed according to the requirements of the local council. Do not expose to fire.
- Warning: Fill with potable water only.
- For cleaning, please refer to “ CARE AND CLEANING” section.

## THE REFRIGERANT (R600A) IS FLAMMABLE.



Warning: Risk of fire / Flammable materials.

The refrigerant isobutene (R600a) is contained within the refrigerant circuit of the appliance. Isobutene has a high level of environmental compatibility, but it is flammable. Make sure that none of the components of the refrigerant circuit are damaged during transportation and installation.

If the refrigerant circuit should be damaged:

- Avoid open flames and sources of ignition.
- Thoroughly ventilate the room in which the appliance is situated.
- Before using the ice maker for the first time, please wait 2 hours after positioning it, and keep the transparent lid open for at least 2 hours.
- Do not switch on the power button frequently (ensure at least a 5-minute interval) to avoid damage to the compressor.
- Never clean with scouring powders or hard cleaning tools.
- To avoid food contamination, please respect the following instructions:
  - Avoid opening the lid for long periods, as this can cause a significant increase in the temperature in the compartments of the appliance.
  - Regularly clean surfaces that can come in contact the water and ice cubes.
  - Clean the water tank if it has not been used for 48 hours.
  - If the refrigerating appliance is left empty for long periods, switch off, defrost, clean, dry, and leave the lid open to prevent mould developing within the appliance.

## WARNING

If the supply power cord is damaged, it must be replaced by a qualified, electrical person only or the appliance must be disposed of, to avoid a hazard.

This product has not been designed for any uses other than those specified in this booklet.

## SAVE THESE INSTRUCTIONS

## FEATURES OF YOUR ICE MAKER

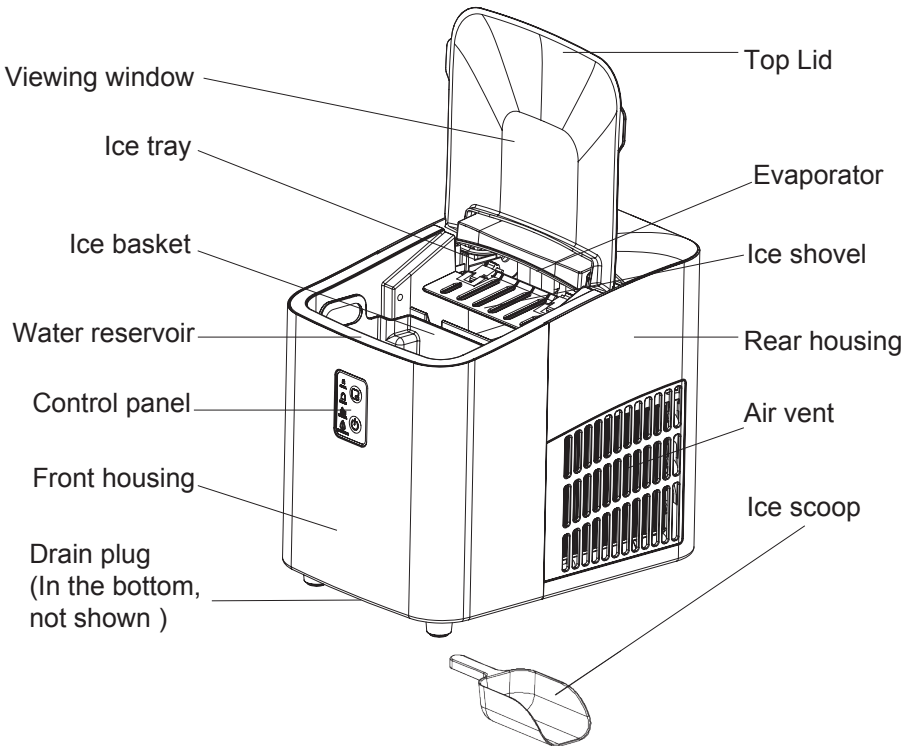

# GETTING TO KNOW YOUR ICE MAKER

Congratulations on the purchase of your new Ice Maker.

Before first using your new Ice Maker, it is most important that you read and follow the instructions in this use and care booklet, even if you feel you are familiar with this type of appliance.

Your attention is drawn particularly to the section dealing with IMPORTANT SAFEGUARDS. Find a safe and convenient place to keep this booklet handy for future reference.

This appliance has been designed to operate from a standard domestic power outlet. It is not intended for industrial or commercial use.

## USING THE APPLIANCE

### Before first use

### **WARNING**

- During transportation, do not tilt the appliance for more than 45 degrees, do not reverse the appliance. This may damage the compressor and the sealing system.
  - Do not use chemicals, acidic or alkaline liquids to make ice.
1. Remove all packing materials, check the appliance carefully and make sure that the appliance, power cord and plug are not damaged.
  2. The appliance should be placed on a level surface. To ensure sufficient ventilation, the distance from the back of the ice maker to the wall should be at least 150mm. The appliance should be kept away from ovens, radiators or other heat sources.
  3. Before using the appliance for the first time, position it and leave the lid open for at least two hours.
  4. Make sure that the home voltage is consistent with the voltage indicated by the appliance.

## Control Panel



Select button

Start/Stop button

Start/Stop button: Start or stop the operation

Select button: Select the sizes of ice cubes

SMALL: Indicator light for small ice cube size

LARGE: Indicator light for large ice cube size

ICE FULL: Illuminate when the ice basket is full

ADD WATER: Illuminate when the water in the reservoir is insufficient

## OPERATION

1. Make sure that the drain plug at the bottom of the water reservoir is closed well.
2. Plug in the ice maker and the appliance is in the standby mode. The “LARGE” indicator flashes in green.
3. Open the top lid and take out the ice basket.
4. Fill the water reservoir with drinking water at temperature between 8-25°C, Max. capacity of water reservoir is 1L.
5. Put back the ice basket and close the top lid.

6. Press the “Select button” to choose the sizes of ice cubes. The corresponding indicator light will light up. Then press the “Start/Stop button” to start operation. A typical ice-making cycle takes approximately 10 minutes, depending on the ambient temperature and water temperature.
- An ice-making cycle starts with water being pumped into the ice basket situated below the evaporator. During the cycle, the bullet ice cubes will form on the evaporator.
  - Once the bullet ice cubes are formed, the Ice tray will tilt backwards and the remaining water will be drained back into the water reservoir.
  - The bullet ice cubes are then dropped from the evaporator and pushed forward into the ice basket by the ice shovel board.
  - The Ice tray will automatically move back to the position under the evaporator. Then the next cycle will begin.
7. Observe through the transparent window. When there is a desired amount of ice cubes, press the “Start/Stop button” to stop the ice-making process. The appliance will return to the standby mode with the “LARGE” indicator flashing and the motor will stop after approximately 30 seconds. Turn off the power outlet if possible and then unplug the appliance. Open the top lid and collect the ice using the ice scoop.

**NOTE: When the ambient temperature is below 15 degrees, it is recommended to select small ice cube size. When the ambient temperature is above 30 degrees, it is recommended to select large ice cube size.**

### **Add water indicator**

When the “ADD WATER” indicator is ON, operation is paused and water should be added to the water reservoir. After adding water, press the “Start/Stop” button twice to restart the appliance.



### **Ice full indicator**

When the “ICE FULL” indicator is ON, the ice has reached the maximum capacity of the ice basket and operation is paused. Open the top lid and use the ice scoop to take out ice cubes. When the ice level is lowered, the appliance will restart automatically.

### **Cleaning function**

Fill water to MAX. level mark on water reservoir, plug in the appliance, press and hold the “Start/Stop button” for 3 seconds to start the cleaning function. When performing the cleaning function, the four indicator lights on the control panel will keep alternating. Do not disconnect the power supply during cleaning. After cleaning, the appliance will enter the standby mode automatically.

## **CARE AND CLEANING**

It is recommended to clean the ice maker once a week and replace the water every 48 hours. Before cleaning, please make sure that the appliance is turned OFF, unplugged and at room temperature.

1. If there is residual water in the ice basket, gently push the ice basket so that the water drains into the water reservoir.
2. Move the ice maker 75mm away from the surface where it is used and open the drain plug to drain out excess water.
3. Remove the ice basket.
4. Clean the interior with a soft cloth soaked with warm water, then rinse with fresh water and let dry. Add white vinegar to the warm water for better cleaning.
5. Reinstall and tighten the drain plug firmly.
6. Wash the ice basket and ice scoop in warm soapy water. Rinse and dry
7. Clean the exterior with a soft damp cloth. Use a mild dishwashing soap if necessary. Then wipe dry.

8. Depending on the use of the appliance, the filter screen in the water reservoir should be cleaned on a regular basis in order to prevent the water inlet from becoming clogged by incrustation scale. As shown in the figure below, take out the ice basket and the filter screen from the water reservoir. Clean the filter screen with a brush and clean water. Then put the filter screen and ice basket in place.
9. If the ice maker will not be used for an extended period, ensure that the water reservoir is empty and all components are dry.
10. Store at a cool, dry place which is away from direct sunlight.

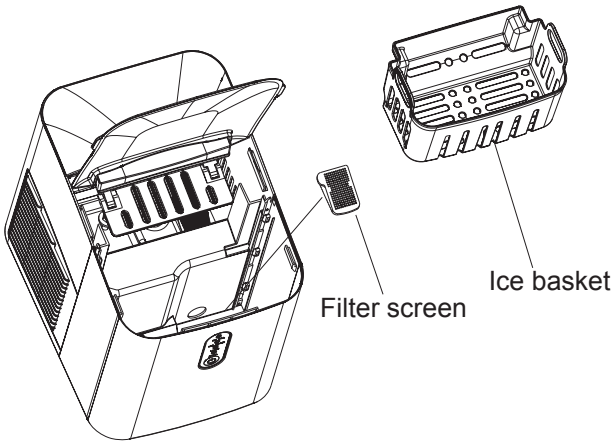

## TECHNICAL SPECIFICATIONS

Voltage: 220-240V~

Frequency: 50Hz

Power: 120W

Rated Current :1 A

Refrigerant (Weight): R600a (14g)

Capacity : Water reservoir MAX. 1.0L; Ice basket MAX. 1.0L

**NOTE: As a result of continual improvements, the design and specifications of the product within may differ slightly to the unit illustrated from the packaging.**

# TROUBLESHOOTING

Issue	Possible cause	Steps to resolve
The “ICE FULL” indicator illuminates.	The ice basket is full.	Remove ice cubes from the ice basket with the ice scoop.
The “ADD WATER” indicator illuminates.	The water in the reservoir is insufficient.	<ol style="list-style-type: none"> <li>1. Add water into the water reservoir until the water level reaches the MAX position.</li> <li>2. Press the START/STOP button twice to restart the appliance.</li> </ol>
	The filter screen at the bottom of the water reservoir is blocked	Unplug the ice maker and clean.
The ice cubes are clumping together.	The ice-making cycle is too long.	<ol style="list-style-type: none"> <li>1. Turn OFF the ice maker to stop making ice.</li> <li>2. Wait until the ice inside melts before restarting.</li> </ol>
	The water temperature is too low.	Refill the water reservoir with water between 8–25°C.
The ice cube maker is operating but not making ice.	The ambient temperature or water temperature is too high.	<ul style="list-style-type: none"> <li>• Ensure the ambient temperature is between 5–32°C.</li> <li>• Refill the water reservoir with water between 8–25°C.</li> </ul>
	The refrigeration system is leaking.	Please contact customer service.
	The refrigeration system is blocked.	Please contact customer service.
All indicator lights flash at the same time.	The water reservoir is blocked by ice.	Unplug the appliance, remove the ice under the ice shovel board, and plug in the appliance. Then press the “Start/Stop” button to restart.
	The motor is faulty.	Please contact customer service.
When the ice basket is full, the ICE FULL” indicator does not light up.	The sensor is faulty.	Please contact customer service.

## 12 MONTH WARRANTY

Thank you for your purchase from Kmart.

Kmart Australia Ltd warrants your new product to be free from defects in materials and workmanship for the period stated above, from the date of purchase, provided that the product is used in accordance with accompanying recommendations or instructions where provided. This warranty is in addition to your rights under the Australian Consumer Law.

Kmart will provide you with your choice of a refund, repair or exchange (where possible) for this product if it becomes defective within the warranty period. Kmart will bear the reasonable expense of claiming the warranty. This warranty will no longer apply where the defect is a result of alteration, accident, misuse, abuse or neglect.

Please retain your receipt as proof of purchase and contact our Customer Service Centre on 1800 124 125 (Australia) or 0800 945 995 (New Zealand) or alternatively, via Customer Help at [Kmart.com.au](https://www.kmart.com.au) for any difficulties with your product. Warranty claims and claims for expense incurred in returning this product can be addressed to our Customer Service Centre at 690 Springvale Rd, Mulgrave Vic 3170.

Our goods come with guarantees that cannot be excluded under the Australian Consumer Law. You are entitled to a replacement or refund for a major failure and compensation for any other reasonably foreseeable loss or damage. You are also entitled to have the goods repaired or replaced if the goods fail to be of acceptable quality and the failure does not amount to a major failure.

For New Zealand customers, this warranty is in addition to statutory rights observed under New Zealand legislation.



Cat. No. KICE669  
July 2023