

# anko

## User Manual

### Portable BBQ Charcoal Grill

Keycode: 42965886

Please read all the information carefully before you use the device, keep it for future reference.

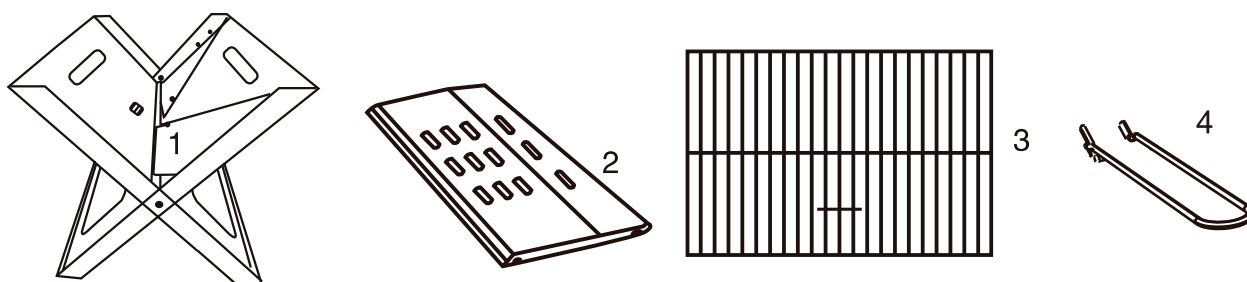

1	<b>Folding Frame</b>
2	<b>Charcoal Pan</b>
3	<b>Cooking Grill</b>
4	<b>Grill Handle</b>

# Installation

## Step 1

Expand Folding Frame 1.

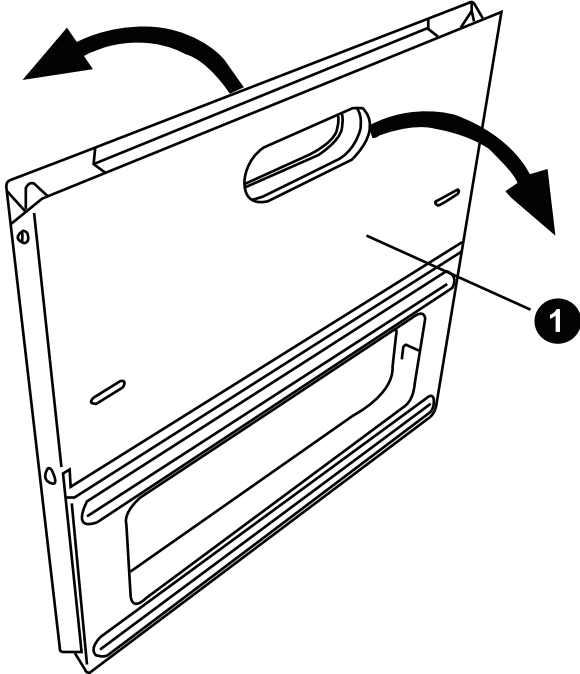

## Step 2

Rotate both(B) and secure them with a retaining clip(C).

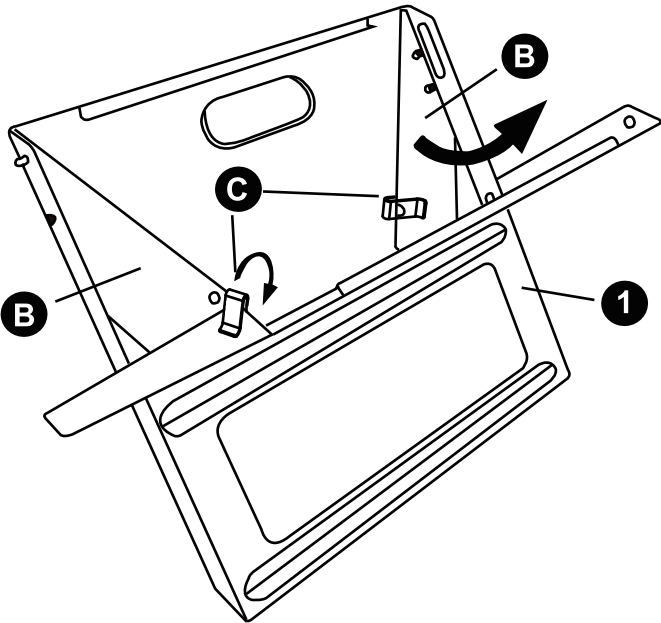

## Step 3

Unfold the carbon disk (2) and insert the two end plates (D) into the basket (2) from above.

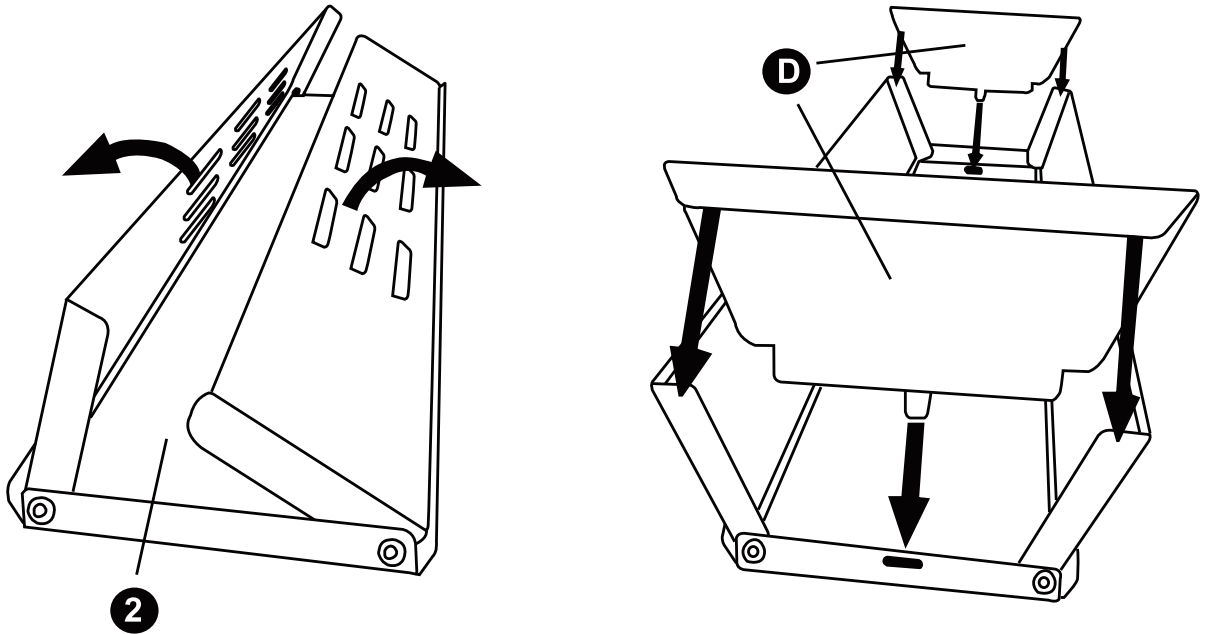

## Step 4

Put the charcoal pan (2) into the folding frame (1). Make sure that the two locking plates (E) are engaged in the grooves of the folding frame (1).

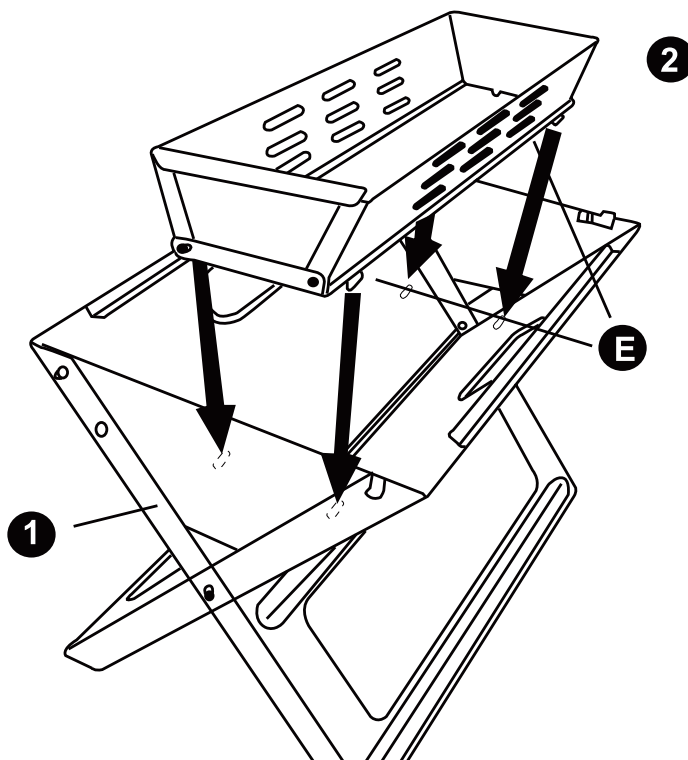

## Step 5

Hang the one handle (4) on the grill(3).

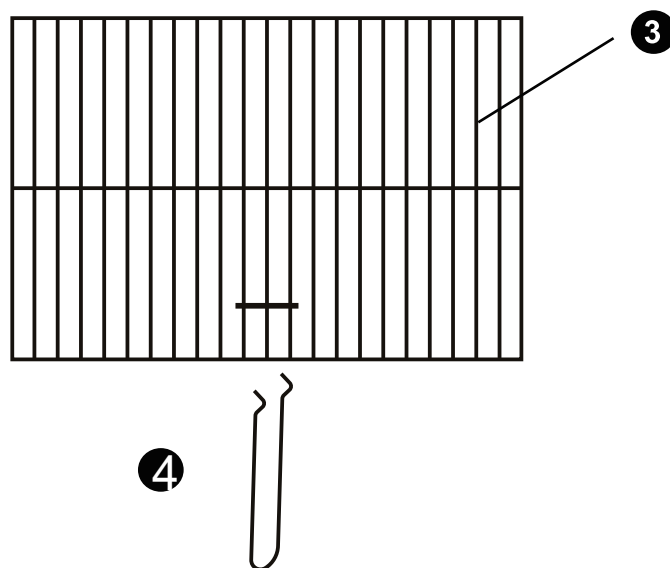

## Step 6

Put the cooking grill(3) on the grill(1).

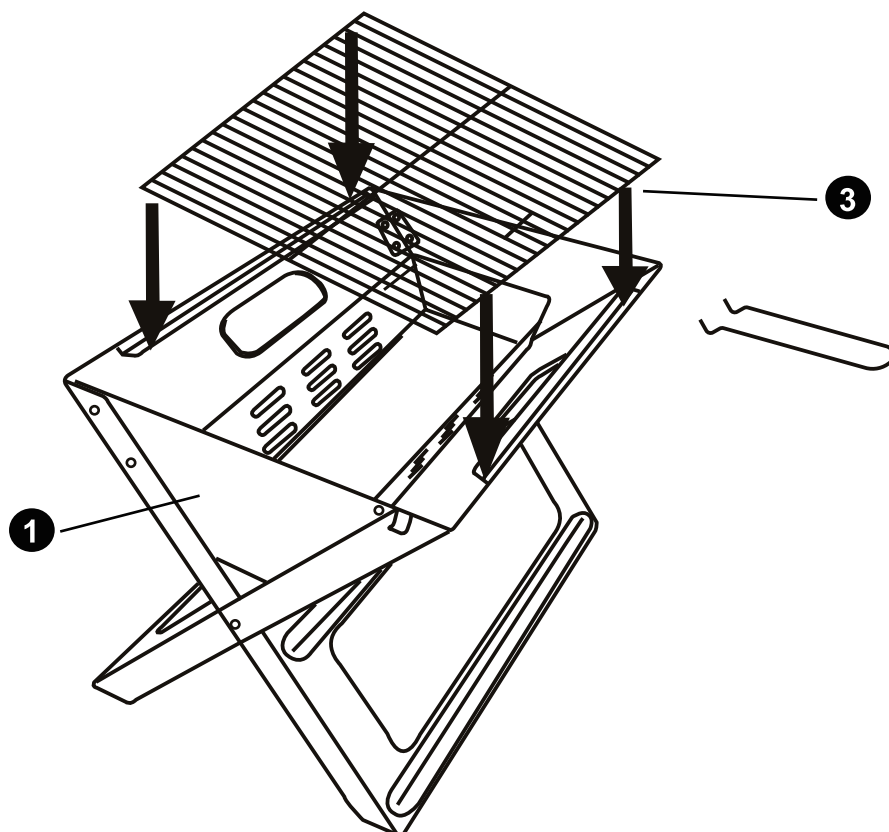

Maximum weight of charcoal is 0.5kg.

## 12 Month Warranty

Thank you for your purchase from Kmart.

Kmart Australia Ltd warrants your new product to be free from defects in materials and workmanship for the period stated above, from the date of purchase, provided that the product is used in accordance with accompanying recommendations or instructions where provided. This warranty is in addition to your rights under the Australian Consumer Law.

Kmart will provide you with your choice of a refund, repair or exchange (where possible) for this product if it becomes defective within the warranty period. Kmart will bear the reasonable expense of claiming the warranty. This warranty will no longer apply where the defect is a result of alteration, accident, misuse, abuse or neglect.

Please retain your receipt as proof of purchase and contact our Customer Service Centre on 1800 124 125 (Australia) or 0800 945 995 (New Zealand) or alternatively, via Customer Help at [Kmart.com.au](https://www.kmart.com.au) for any difficulties with your product. Warranty claims and claims for expense incurred in returning this product can be addressed to our Customer Service Centre at 690 Springvale Rd, Mulgrave Vic 3170.

Our goods come with guarantees that cannot be excluded under the Australian Consumer Law. You are entitled to a replacement or refund for a major failure and compensation for any other reasonably foreseeable loss or damage. You are also entitled to have the goods repaired or replaced if the goods fail to be of acceptable quality and the failure does not amount to a major failure.

For New Zealand customers, this warranty is in addition to statutory rights observed under New Zealand legislation.