

42947912
Galaxy Tracker® 375 Smart Telescope



COMPONENTS OF THE TELESCOPE

- | | |
|--------------------|-----------------------------|
| 1. Focusing Knob | 8. Objective Lens |
| 2. Focusing Tube | 9. Bracket |
| 3. Diagonal Mirror | 10. Barlow Lens |
| 4. Eyepiece | 11. Smartphone Adapter |
| 5. Telescope Tube | 12. Smartphone Adapter Knob |
| 6. Tripod Legs | |
| 7. Knob bolt | |

WARNING ! NOT SUITABLE FOR CHILDREN UNDER 36 MONTHS DUE TO SMALL PARTS. CHOKING HAZARD. THIS TELESCOPE SET IS APPROPRIATE FOR CHILDREN OVER 8 YEARS OLD. TO BE USED UNDER THE DIRECT SUPERVISION OF ADULTS.

CAUTION ! DO NOT VIEW SUN THROUGH TELESCOPE AS SERIOUS INJURY TO EYE MAY RESULT.

Read the following information and instructions before use. Follow them and keep them for reference.

M-32015-ENG

A) HOW TO CARE FOR YOUR TELESCOPE

Appropriate care of the telescope will allow many years of pleasant viewing enjoyment.

The Objective Lens

The objective lens of Telescope has been intensely polished and established to minute tolerances. It must be cleaned with care and as seldom as possible to avoid affecting its precision and performance. An inexperienced person must never take the lenses out of their mount.

Cleaning The Lens

Clean the lens only when it is required. The first step is to remove the dust with a camelhair brush or an ear-type syringe. Set few drops of ether or isopropyl alcohol on a piece of clean cotton that has been washed several times and wipe the lenses very delicately, avoiding a circular motion. In addition, blow any remaining lint or dust off with an ear-type syringe.

Sudden Temperature Changes

If possible, avoid taking the telescope from cold outside air into a warm room. This will make the objective lens covered with condensed moisture, which must be removed at once. To do this, place the objective lens at a safe distance from heat source and let it warm slowly until the moisture has vanished.

It is important to note that any stains left on the lenses must be delicately wiped off after the lenses are completely dry.

Features:

Professional aspherical lens for super sharp images

This telescope employs aspherical lenses to reduce image aberration often found in conventional spherical lens elements, producing a sharp and less distorted image from the center to the edge of the field of view.

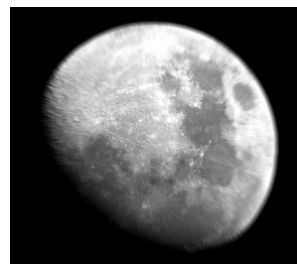

Image from spherical lens



Image from aspherical lens

Wide angle view

This telescope employs wide angle eyepieces, which offer a larger view of the sky while still retaining the same magnification, giving a greater area of sky coverage.

B) HELPFUL HINTS FOR SETTING UP THE TELESCOPE

Tripod Set-Up

1. Remove the tripod from the box.
2. Spread tripod legs (6) so that the leg braces are fully extended and rest safely at the base of the tripod center post.
3. Fasten all locks to hold legs securely in place.
4. Temporarily remove the knob bolt.

Telescope Set-Up

1. Take out the Telescope Tube (5) from the box.
2. Put the telescope on the tripod such that the holes of the bracket (9) align with the tripod's knob bolt position. Re-install and tighten the knob bolt.

Putting In Diagonal Mirror & Eyepiece

1. Insert diagonal mirror (3) into focusing tube (2). Secure by tightening the small retaining screw.
2. Install the soft eyepiece cap over the eyepiece (4) if needed. Insert eyepiece (4) into diagonal mirror (3). Secure by tightening the small retaining screw.

Putting In The Barlow Lens

1. Remove the diagonal mirror (3) and insert the Barlow lens (10) into the focusing tube (2).
2. Now the eyepiece can then be inserted into the Barlow lens. If needed, diagonal mirror should be installed between the Barlow lens and the focusing tube.

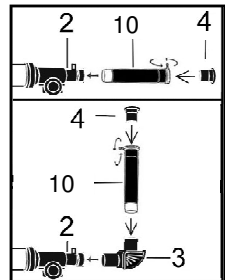

C) OBSERVING ASTRONOMICAL OBJECTS THROUGH YOUR TELESCOPE

1. Glance through the main telescope's eyepiece (4) for your object. (Note : You may have to alter the angle of the telescope slightly.) The object will most likely seem to be blurry at this stage, but that is normal. You are just trying to get the object in the viewing field of your telescope lens. Once you have accomplished this task, fasten the knobs to keep the accuracy of your telescope steady.
2. Now adjust the Focusing Tube (2) by turning the Focusing Knob (1) slowly back and forth until the blurred object becomes precise.
3. If you are going to be looking through the telescope for a short period of time, you can insert the Eyepiece directly into the Focusing Tube. To be more comfortable when using your telescope for longer periods of time, place the Diagonal Mirror (3) into the Focusing Tube and the Eyepiece into the Diagonal Mirror.

D) HOW TO USE THE TELESCOPE

Our telescope offers an extensive selection of parts and accessories for your telescope to further enhance the exploration of worlds beyond. As well, it is a precision optical instrument certain to give many years of enjoyment and entertainment.

i. Viewing

What you see through a telescope and how accurate you see it is a function of three factors ;

- Power / Magnification
- Brightness
- Resolution / Clarity of image

It is a common misunderstanding that the more power you have, the better it is. Indeed, essential functions of a telescope are to magnify the image, or give the effect of being closer to object of observation. However, there are limits to how much power to use effectively. With every increase in magnification, there is a corresponding reduction of brightness and resolution. Too much magnification and the image will become dim and blurry so that the features of the object become vague. For best view of any astronomical body, you must strike a balance between the three viewing qualities.

Furthermore, with every increase in power, there is a decrease in field of view. The field of view is the circle of sky you see as you look through your telescope. The more you increase magnification, the smaller that circle becomes. You will also notice that celestial bodies seem to move fast across the field of view even at low powers. That movement is still more recognizable at high powers. High power will provide some dramatic views of lunar or planetary features, but can also be somewhat frustrating until you acquire a certain level of expertise at tracking objects smoothly.

ii. Power Strength : Selecting The Eye Lens

Power means the ability of telescope to increase an image, or appear to bring the image closer to the viewer. Value of magnifying power is distinguished by a number followed by an X (read power). Therefore, If you view an object at 125X, you are seeing it as though you are 125 times closer to that object.

Power is calculated by dividing the focal length of objective lens of your telescope by the focal length of the eye lens you choose. The focal length of the eye lens is usually indicated on the eyepiece itself. For example : 4mm

$$\text{Example: } \frac{500 \text{ mm (focal length of objective lens)}}{4 \text{ mm (focal length of eyepiece)}} = 125 \text{ X (power)}$$

The longer the focal length of the eyepiece, the less the magnifying power of the telescope. Whereas the shorter the focal length, the greater the power. Therefore, when choosing an eye lens to insert the diagonal prism, you are actually selecting what magnifying power you wish to use for inspection.

E) USING THE SMARTPHONE ADAPTER

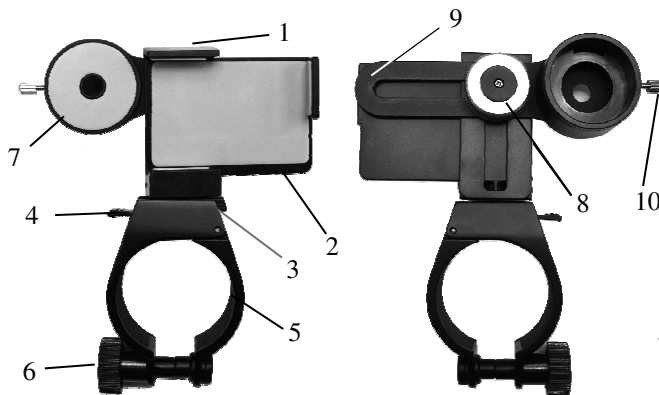

Components of the Smartphone Adapter

1. Adjustable arm
2. Smartphone holder
3. Bracket
4. Quick release lever
5. Arc
6. Small knob
7. Eyepiece adapter
8. Large knob
9. Swing arm
10. Small screw

i. Attach The Smartphone To The Adapter

1) If the telescope clip (lower half) is connected to the smartphone holder, separate them by pressing the quick release lever (4) and sliding out.

2) Loosen the large knob (8) at the back of the adaptor and put the smartphone on it with face up.

3) Adjust the position of the horizontal arm (1) to fit the width of the smartphone and tighten the large knob (8) just enough to keep the phone in position.

4) Align the centre of the adaptor hole of the swing arm (9) to the smartphone camera.

Tighten the screw so that the smartphone is securely held in place.

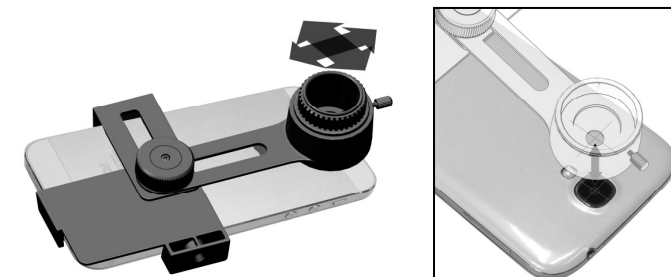
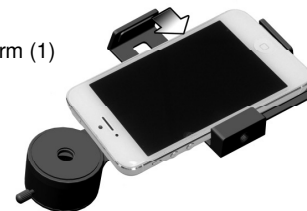

5) Loosen the small knob (6) on the base of the clip and open the arc of the ring (5).

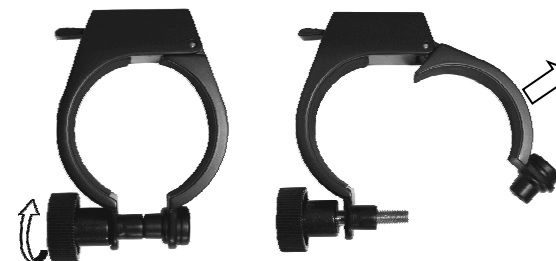

6) Attach clip to the telescope tube with the flat side in upper position.

7) Close the ring, secure by tightening the small knob (6).



8) Slide the smartphone adapter to the telescope clip.



ii Using STAR WALK™ 2

A stargazing smartphone software application (e.g. Star Walk™ 2 for iOS and Android) helps you find and identify the celestial objects easily.

Select "Take a Tour" (Menu  → Take a tour) to familiarize yourself with the various app features.

The App language will follow your smartphone's language setting.

Features Highlight:

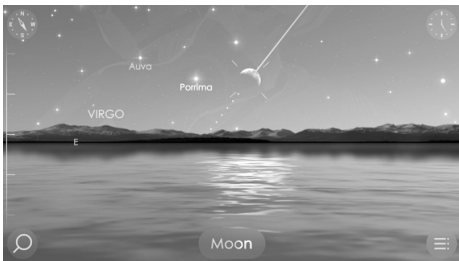

IDENTIFY THE CELESTIAL OBJECTS

After the smartphone adapter is attached to the telescope, the smartphone orientation is aligned with the telescope. Utilizing the smartphone's location and orientation, a star map application can show the real time simulated sky view on the screen matching the view through the telescope. Names of the stars or celestial objects are shown on screen and automatically updated when users adjust the telescope or move the telescope to a different location.

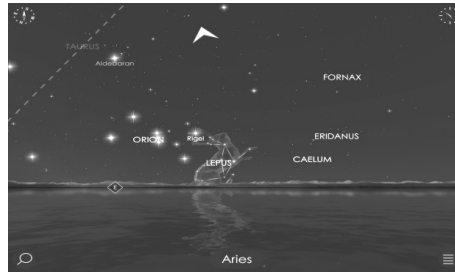

SEARCH AND DIRECT

Another advantage of using the application software is that users can search for a celestial object. The screen will guide users which direction to move the telescope.

iii. Using The Smartphone Eyepiece Adapter

The smartphone adapter is also equipped with an adapter to attach to the telescope eyepiece for photo and video capture..

1. To remove the adapter from the telescope, press the quick release lever (4) and slide the smartphone adaptor out.



2. Loosen the small screw (10) at the top. Attach the adaptor-smartphone assembly to the telescope eyepiece as shown. The adaptor should be fully inserted into the eyepiece for best results. Tighten the small screw



3. With the camera app opened, re-adjust the smartphone camera position by slightly loosening the main adaptor screw if necessary. The image circle should be at the centre of the screen. Adjust the focus knob until the image is clear.

F) TECHNICAL SPECIFICATIONS

Objective Diameter	:	50 mm (1.97")
Focal Length	:	500 mm
Eyepiece Diameter	:	1.25" (31.7mm)
Eyepieces Focal Length	:	20 mm, 4 mm
Barlow Lens	:	3 X
Maximum Magnification	:	375X
Accessories	:	Smartphone Adapter, Diagonal Mirror, 95cm Extendable Aluminium Tripod, 3X Barlow Lens

Eyepiece Chart & Power Limits

Eyepiece	Power	Power with 3X Barlow Lens
20 mm	25X	75 X
4 mm	125X	375 X

Enjoy using your New Generation Smart Telescope!

All Rights Reserved.