



INSTRUCTIONS

CREATE COLOURFUL RUBBER BRACELETS

LOOM BASICS

IT'S SO MUCH FUN MAKING RUBBER BAND LOOM BRACELETS. FOLLOW THE INSTRUCTIONS TO LEARN THE BASICS AND MAKE BEAUTIFUL LOOM BRACELETS. HAVE LOOM-TASTIC FUN!



PLACING

ENSURE THE PEGS ARE IN THE CORRECT POSITION, FACING UPWARDS

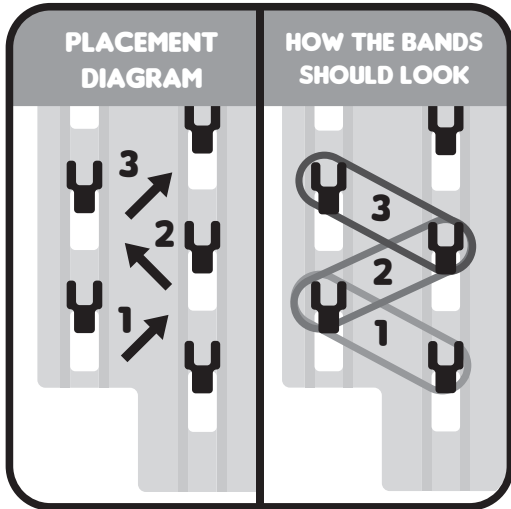

PLACE THE RUBBER BANDS ON THE EXACT PEGS AND IN THE ORDER SHOWN ON THE PLACEMENT DIAGRAM.



THE BASIC SKILL PICKING AND LOOPING

WHEN PICKING AND LOOPING BANDS, ENSURE THAT THE PEGS ARE FACING DOWNWARD

TIP: MAKE SURE TO ALWAYS PICK AND LOOP THE SAME BAND ONTO ITSELF!

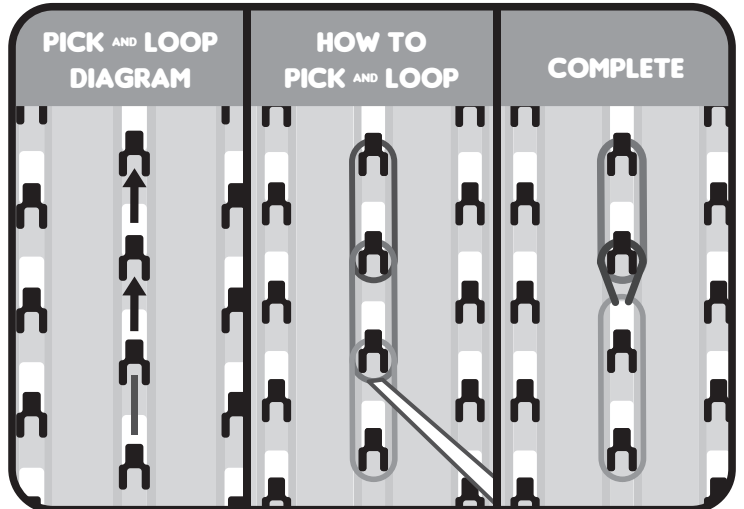

FLIP THE LOOM

PICK & LOOP THE BANDS IN THE EXACT ORDER SHOWN IN THE PICK & LOOP DIAGRAM. USE THE HOOK TO PICK THE BANDS OFF ONE PEG AND LOOP THEM ONTO ANOTHER.

TIP: HOLD DOWN THE OTHER BANDS WITH YOUR FINGER SO THEY DON'T COME LOOSE OFF THE PEGS.

MORE BASICS

ADDING CAPS

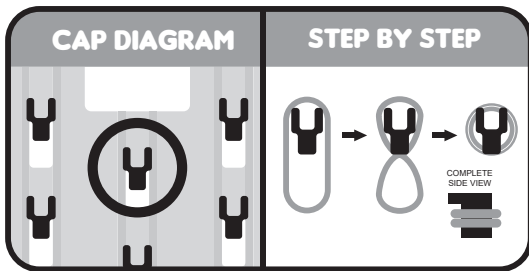

TO CREATE A CAP, LOOP 1 RUBBER BAND AROUND THE DESIGNATED PEG 2 TIMES. DON'T LET THE CAP BAND OVERLAP ONTO THE BANDS BELOW.

ADDING A SLIP KNOT

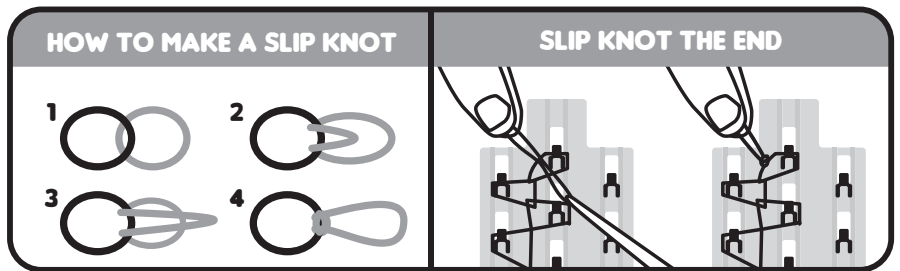

SLIP KNOTS ARE VERY IMPORTANT. ALWAYS MAKE SURE WHEN YOU ARE FINISHED PICKING AND LOOPING, THAT YOU ADD A SLIP KNOT TO YOUR LOOM DESIGN.

1. THREAD A BAND THROUGH THE BANDS(S) ON THE LAST PEG YOU LOOPED.

2. LOOP ONE END OF THE SINGLE BAND THROUGH THE OTHER, AND PULL TIGHT

REMOVING YOUR DESIGN FROM THE LOOM AND USING S-CLIPS

REMOVE

WHEN YOU HAVE TIED YOUR SLIP KNOT, CAREFULLY REMOVE YOUR DESIGN FROM THE LOOM. ALWAYS START FROM THE BOTTOM AND GENTLY PULL THE BANDS OFF EACH PEG.

S-CLIP

CONNECT THE TWO ENDS OF THE BRACELET WITH AN S-CLIP.

HELPFUL TIPS

WHAT TO DO IF A BAND BREAKS?

UNFORTUNATELY FROM TIME TO TIME BANDS CAN BREAK. IF THIS HAPPENS TO THE BAND THAT YOU'RE UP TO/CURRENTLY WORKING WITH, SIMPLY CHOOSE ANOTHER BAND. HOWEVER, IF IT HAPPENS FURTHER DOWN YOUR DESIGN, YOU'LL UNFORTUNATELY NEED TO START AGAIN.

SLIP KNOT ENDS

IF YOU DON'T KNOT THE END OF YOUR LOOM BRACELET, IT WILL FALL APART. MAKE SURE TO CHECK YOU HAVE A SLIP KNOT BEFORE REMOVING THE BRACELET FROM YOUR LOOM.

PICKING

IF YOU ARE NEW TO RUBBER BAND MAKING, LEARNING HOW TO PICK & LOOP CAN BE TRICKY AT FIRST. BUT WITH PRACTICE YOU WILL BE A LOOM MASTER IN NO TIME!



INSTRUCTIONS

CREATE COLOURFUL RUBBER BRACELETS

MAKE A SINGLE LOOM

WHAT YOU NEED: 28 BANDS, 1 S-CLIP

HOW TO: FOLLOW THE PLACEMENT DIAGRAM AND PLACE ONE BAND PER PEG. FLIP THE LOOM THEN FOLLOW THE PICK & LOOP DIRECTIONS. REMEMBER TO ADD A SLIP KNOT AT THE END. REMOVE THE BANDS THEN ADD THE S-CLIP.

PLACE

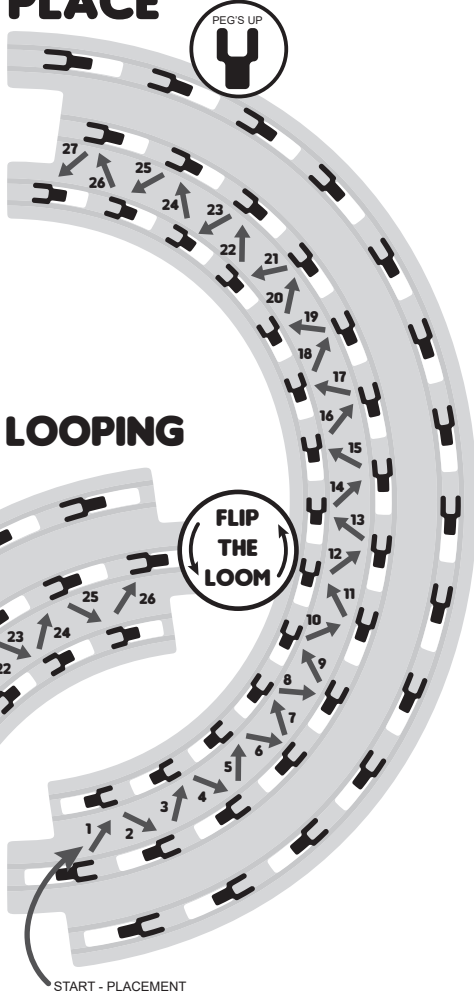

PICKING AND LOOPING

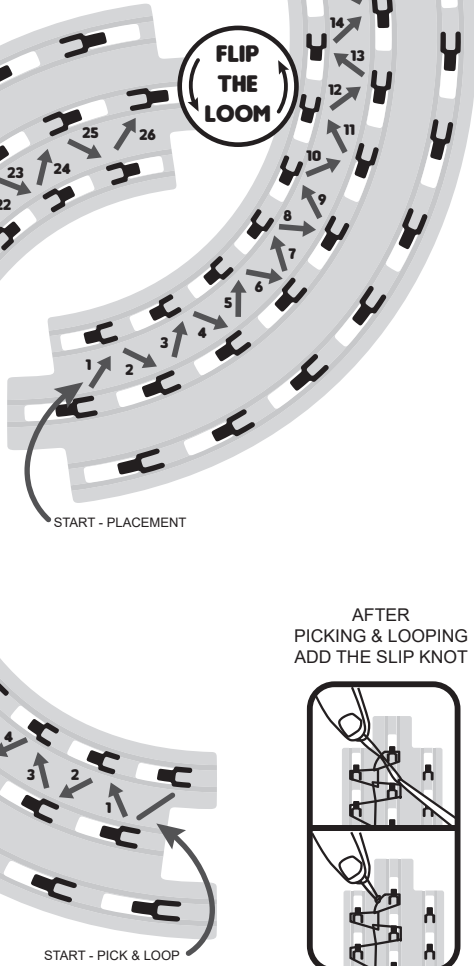

AFTER PICKING & LOOPING ADD THE SLIP KNOT

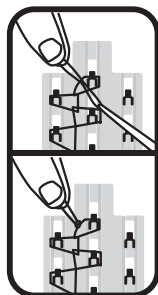

START - PICK & LOOP

WARNING: This product is not suitable for children under 6 years due to potential choking hazard. Do not wear bracelets around neck. Always make sure bracelet is loose enough to not cause any irritation or cut off circulation. Discontinue use if skin redness develops.

MAKE A WATERFALL LOOM

WHAT YOU NEED: 55 BANDS

HOW TO: FOLLOW THE PLACEMENT DIAGRAMS 1&2. BEFORE PLACING BANDS IN TRIANGLE SHAPES (STEP 2) PUSH DOWN THE BANDS ON THE PEGS. FLIP THE LOOM THEN FOLLOW THE PICKING & LOOPING DIRECTIONS. REMEMBER TO ADD A SLIP KNOT AT THE END. CAREFULLY REMOVE THE BANDS THEN ADD THE S-CLIP.

START - PLACE 1

PLACE - STEP 1



CONTINUE - PLACE 2

PLACE - STEP 2



PICKING AND LOOPING

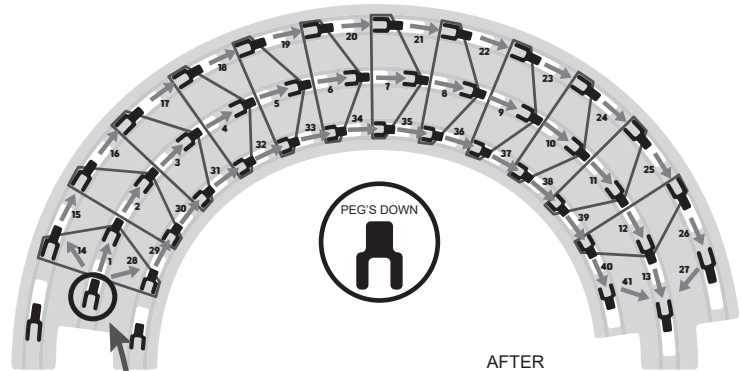

START - PICK & LOOP

TIP: IT CAN BE TRICKY TO PICK FROM THE CAPPED PEG. IN ORDER TO MAKE IT EASIER, GRAB THE FIRST BAND UNDER THE CAP THEN CONTINUE PICKING AND LOOPING FROM PEG 1-13.

CONTINUE THIS ALL THE WAY THROUGH THE LOOM, FOLLOWING THE ABOVE PICKING AND LOOPING DIAGRAM.

AFTER PICKING & LOOPING ADD THE SLIP KNOT

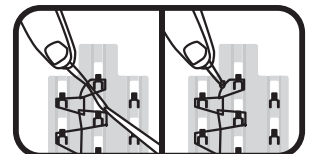

PAULINDA INDUSTRIES (1999) HONG KONG LIMITED
 MANUFACTURER:
 PAULINDA Industries (1999) Ltd.
 No.2 BangXing Road, MaoShan Industrial Zone,
 JiangShan YinZhou Ningbo China 315193



INSTRUCTIONS

CREATE COLOURFUL RUBBER BRACELETS

USING LOOM MINI

WHAT YOU NEED: 50 BANDS, 1 S-CLIP

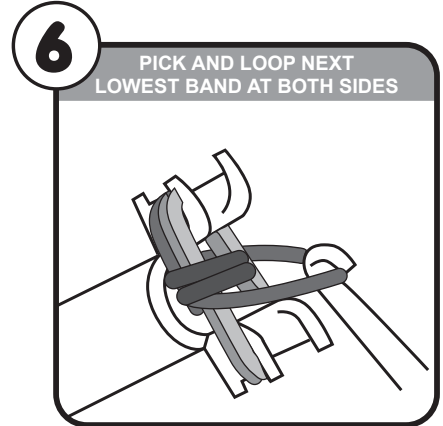
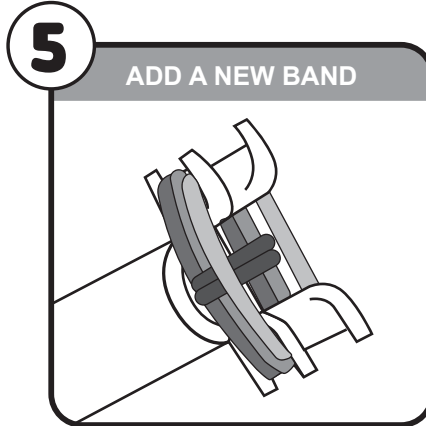
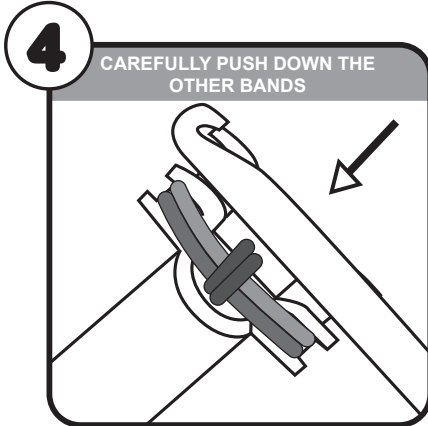
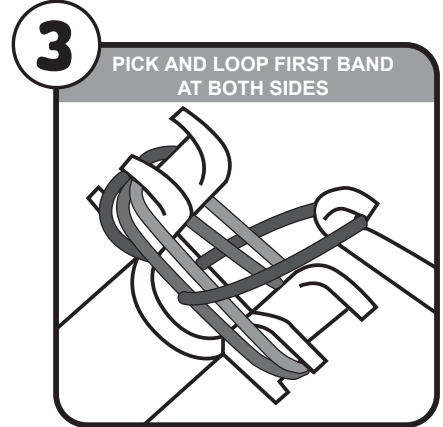
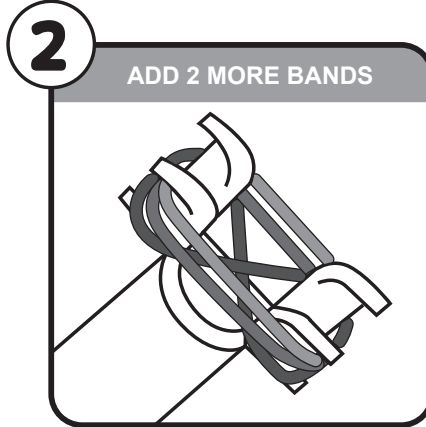
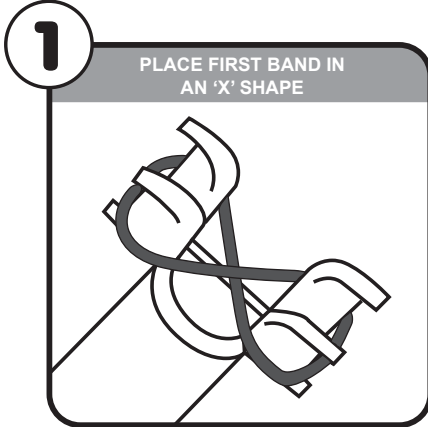

REPEAT STEPS 3 THROUGH 6 UNTIL YOU'RE HAPPY WITH THE LENGTH OF BRACELET.

PROCEED TO FOLLOW STEPS 7 THROUGH 10 TO COMPLETE.

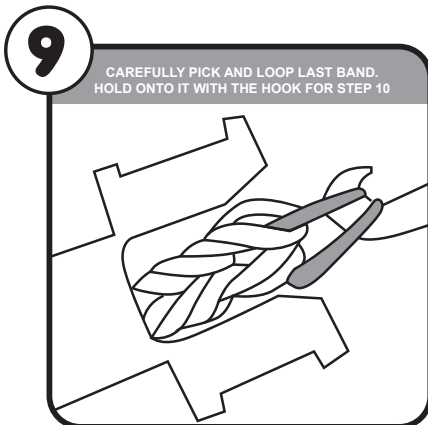
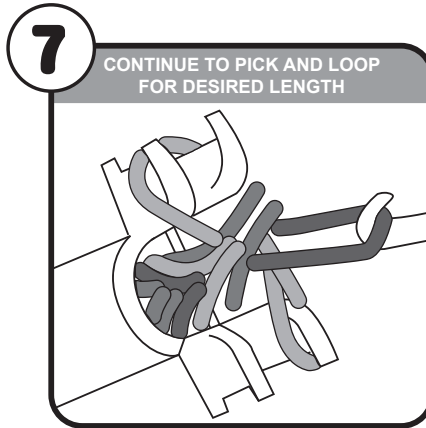

DON'T FORGET

ADD SLIP KNOT
AFTER PICKING & LOOPING
ADD THE SLIP KNOT

S-CLIP
CONNECT THE TWO ENDS OF THE BRACELET WITH AN S-CLIP.