

anko

**Air Fryer
AFD24516
User Manual**



**PLEASE READ AND SAVE THESE
INSTRUCTIONS FOR FUTURE REFERENCE**

IMPORTANT SAFEGUARDS

When using any electrical product, always follow these basic safety precautions:



READ ALL INSTRUCTIONS BEFORE USE.

1. Read all instructions before using this appliance.
2. Always turn the appliance OFF and disconnect from mains power when not in use, before attempting to move the appliance, before cleaning or storing.
3. Never immerse the appliance, the supply cord and plug in water or any other liquid, nor rinse them under the tap.
4. To prevent electric shock and short-circuit, avoid any liquid from entering the appliance.
5. If the supply cord or any part is damaged, it must be replaced by a qualified electrician only or the product must be disposed.
6. Unplug from outlet when not in use and before cleaning. Allow the appliance to cool down before putting on or taking off parts.
7. This appliance is not intended for use by persons (including children) with reduced physical, sensory or mental capabilities, or lack of experience and knowledge, unless they have been given supervision or instructions concerning use of the appliance by a person responsible for their safety.
8. Do not leave the appliance unattended when in use. Children should be supervised to ensure that they do not play with the appliance.
9. Surfaces may become hot during use. This is normal and avoid coming in contact with hot surfaces.
10. Do not let the cord touch hot surfaces, become knotted or hang from the edge of bench tops.
11. Do not place this appliance on or near a hot gas or electric burner, or where it could touch a heated oven.
12. Keep the appliance clear of walls, curtains and other heat sensitive materials (leave a minimum distance of 20cm in each direction). Do not place the appliance under shelving or flammable materials when in use.
13. Do not move the appliance when in use.
14. Do not cover the air inlet or the air outlet when the appliance is working.
15. Do not touch the inside of the appliance while it is working.
16. Do not use the appliance for any other purpose than described in this manual.
17. Do not place anything on top of the appliance when in use and when stored.
18. Before connecting the appliance to the power supply, check that the voltage indicated on the appliance corresponds with the voltage in your home. If this is not the case, DO NOT use the appliance.
19. This appliance is not intended to be operated by means of an external timer or a separate remote-control system.
20. The use of accessories not recommended by the appliance manufacturer may cause serious injury or damage to the appliance.

21. This appliance is for household use only. Do not use this appliance for anything other than its intended use. Do not use it in moving vehicles or boats. Do not use it outdoors.
22. This appliance is not intended to be used in environments such as staff kitchen in shops, offices, farms or other work environments. Nor is it intended to be used by clients in motels, bed and breakfast and other residential environments.
23. During hot air frying, hot steam is released through the air outlet. Keep yourself at a safe distance from steam and the air outlet. Also, be careful of hot steam and air when operating.
24. Make sure the ingredients prepared in this appliance come out golden yellow instead of dark or brown.



CAUTION: Hot surfaces! The appliance and accessories become extremely HOT during cooking process. Do not touch the accessories during and immediately after cooking. Only hold the appliance by the handle and use caution when removing the accessories and food from the appliance. Always wear oven mitts when handling potentially hot accessories and foods. Allow it to cool down completely before cleaning.

IMPORTANT!

- Use the appliance only on a dry, level, stable, and heat-resistant surface only, away from any edges.
- Do not use the appliance under overhead cabinets or presses. The steam may cause damage to the cabinets or presses.
- Do not place the unit close to flammable materials, heating units or wet environments.
- This appliance must be earthed.
- Never use the appliance with oil. Using oil can cause a fire.
- Always unplug the power cord from wall outlet socket when the appliance is not in use.
- Always allow the appliance to cool down completely before cleaning.
- Do not replace with other parts that are not designed specifically for this appliance.
- Do not put any other cooking pans in the appliance.
- If a lot of smoke is escaping from the air vent during operation, unplug the unit and do not use.
- Do not move the unit whilst in operation. Allow the appliance to cool down completely before moving.
- Any repairs to the product must be carried out by a qualified electrical person only.
- Do not disassemble the unit on your own or replace any parts.
- If the power cord is damaged or shows any signs of wear & tear, do not use.
- Keep the unit out of reach of children during use or when stored.
- Keep away from the air outlet or where heat or steam is being released.
- Make sure the appliance is always clean prior to cooking.
- It is normal for some smoke to escape from the unit when heating for the first time. This should subside after few minutes of use.
- For cleaning, please refer to “CLEANING AND STORAGE” section.

WARNING: To prevent risk of severe personal injury and/or property damage, use extreme caution when cooking.

 **CAUTION!**

- **Do not cover the air inlet and outlet opening while the appliance is operating.**
- **Never touch the inside of the appliance while it is operating.**

**SAVE THESE INSTRUCTIONS
FOR HOUSEHOLD USE ONLY**

KNOW YOUR AIR FRYER

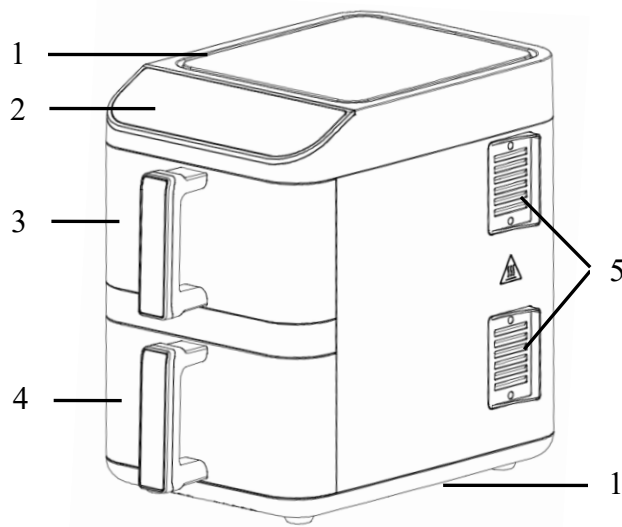

- 1. Air inlet
- 2. Control panel
- 3. Pan 1
- 4. Pan 2
- 5. Hot air outlet
- 6. Main unit
- 7. Crisper plate
- 8. Pan handle

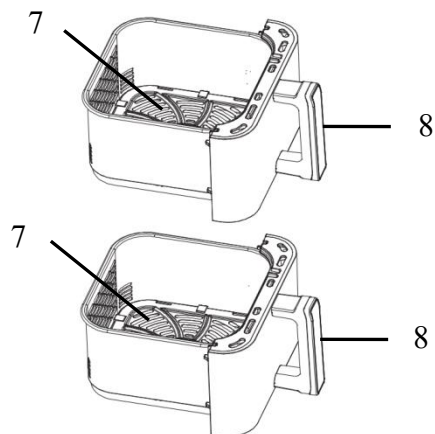
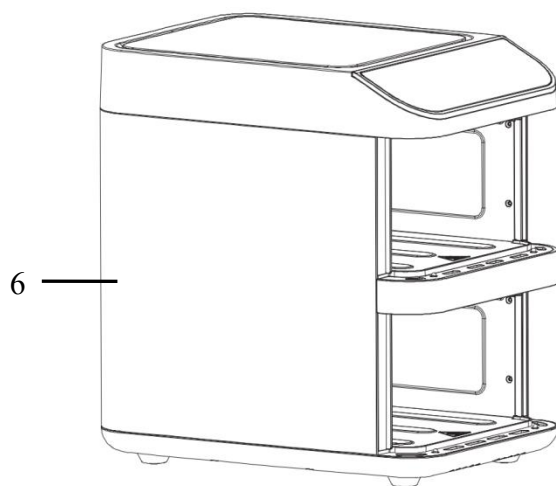

IMPORTANT!



Please make sure that your appliance is received with the right components shown above. Check everything carefully before using it. If any parts are missing or damaged, do not use. Return the product back to place of purchase for replacement.

INTRODUCTION

The air fryer provides an easy and healthier way of cooking your favorite foods. By applying rapid air circulation from all directions, it can cook a variety of dishes without adding any oil or cook with mist of oil.

BEFORE FIRST USE

Note: When using the appliance for the first time, carefully remove all internal and external packaging, protective film and accessories.

- Clean the main unit with a damp cloth or sponge. Wipe dry with a soft dry cloth.
-  **WARNING! Do not immerse the main unit in water or any other liquids to clean.**
- Wash the accessories with soapy water. Dry all components thoroughly before use.
-  **WARNING! This is an oil-free fryer that works on hot air. Do not fill with oil, frying fat or any other liquid. If these instructions are not followed this may cause Fire and/or personal injury.**

HOW TO USE THE CONTROL PANEL

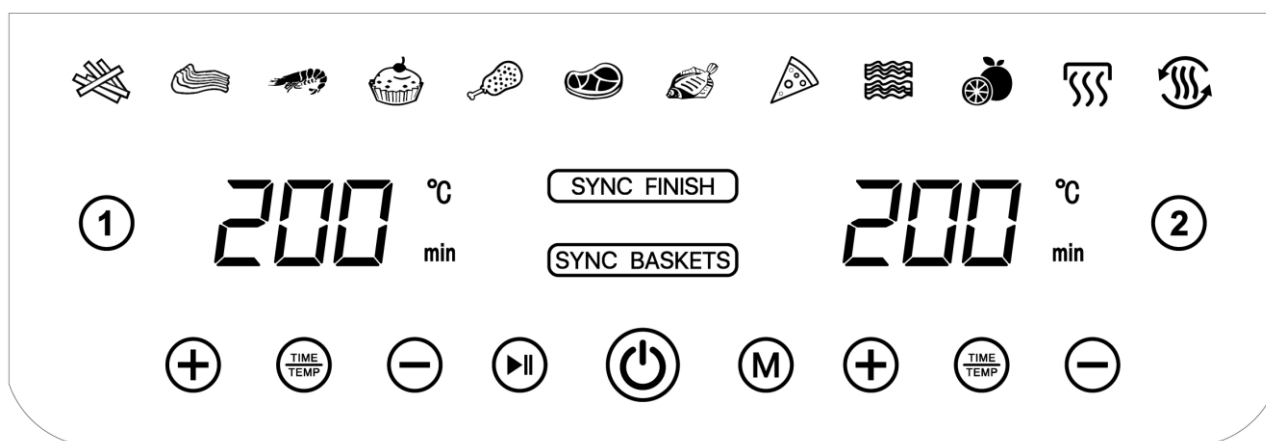

Power Button

- Once the appliance is plugged in, the Power Button will light up and the appliance is in standby mode.
- Touch the power button, it shows pan 1 and 2 on the control panel.
- Touch the power button at any time during the cooking process, the control panel will switch OFF immediately and the appliance will return to standby mode at the same time.

1. Pan Buttons

- Touch pan 1 or 2 to light up the control panel for setting.

2. Preset Function Select Button













- Touch the button to select a preset cook function, the corresponding icon flashes.

3. Preset Functions

- The preset functions will help you to start cooking efficiently.

- Select any of the icons, this will automatically set the Time and Temperature to a default setting for the selected food type. You can over-ride the default presets with time and temperature buttons. The chosen icon will keep blinking until the cooking process has started.
- The preset settings are as follows:

Note: The table below is for reference only. Actual cooking time and temperature may have to be adjusted depending on the food quantity and size.

Icons	Preset	Time	Temperature
	Chips	20 minutes	220°C
	Chops	18 minutes	200°C
	Prawns	20 minutes	180°C
	Baking	25 minutes	160°C
	Drumsticks	20 minutes	220°C
	Steaks	12 minutes	180°C
	Fish	15 minutes	180°C
	Pizza	12 minutes	180°C
	Bacon	15 minutes	160°C
	dehydrator	480 minutes	50°C
	Heating	10 minutes	180°C
	Defrost	30 minutes	50°C

4. Time/temperature Choose Button

- Touch the time/temperature choose button for the corresponding pan to transform time or temperature that you want to reset.
- The selected item (time or temperature) displays for setting.

5. Time/temperature Setting Buttons

- Use the time/temperature setting button for the cooking time and temperature of the corresponding pan setting.

- Time/temperature setting buttons enable you to select exact cooking time by minute. You can increase or decrease time by 30 minutes from 30 to 990 minutes under dehydrator function, by 1 minute from 1 to 60 minutes under other function,
- Time/temperature setting buttons enable you to raise or lower cooking temperature by 5°C starting from 50°C to 120°C under preset function of dehydrator and defrost, 60°C to 200°C under preset function of heating, 140°C to 220°C under other function, you can touch the time/temperature setting buttons to set the time/temperature before or during cooking.
- Touch and hold the time/temperature setting buttons for faster running of the time/temperature.

6. Digital Display

- The Digital Display shows the time and temperature in alternate turns.
- It shows set time and temperature during setting and the remaining time and cooking temperature during cooking.
- Check the correct time and temperature for the corresponding pan.

7. Start/Stop Button

- Touch the start/stop button to start cooking.
- You can stop the cooking process at any time during cooking by touching the start/stop button again.

8. Synchronously Finish Button

- This button enables you to get different foods ready at the same time.
- After setting cooking function or time and temperature for both pans, touch SYNC FINISH button. When cooking starts, one pan will be cooking while the other pan will hold until the times synchronous.

9. Synchronously cook Setting Button

- This button helps with quick setting if you need to set the same function or the same time and temperature for both pans.
- After choosing both pans, touch SYNC BASKETS button. Then choose a preset function or override the time and temperature to your desired setting, now both pans are with the same setting.

INTRODUCTION

The air fryer provides an easy and healthier way of cooking your favorite foods. By applying rapid air circulation from all directions, it can cook a variety of dishes without adding any oil or adding just a little oil to specific ingredients in the table shown in this booklet.

BEFORE USING AIR FRYER

1. Remove all the packing materials including any in the pans.
2. Slide out the pans. Clean pans and drip trays with a non-abrasive sponge, with hot water and dish washing liquid. Rinse with clean water and set aside to dry.
3. Wipe clean the inside and outside of the appliance with a moist soft cloth.
4. Place the appliance on a stable, horizontal, flat and heat-resistant surface.

IMPORTANT! Place the appliance on a heat-resistant surface only. Not recommended to use directly on laminated/vinyl bench top. To prevent heat damage to surface underneath, placing the air fryer on an insulated heat pad is recommended.

COOKING WITH YOUR AIR FRYER

1. Connect the supply cord plug into a mains power outlet socket. The appliance is now in standby mode.
2. Place the ingredients into the pans.

Do not fill more than 2.2kg food in each basket or over the MAX line in the pan.

3. Slide the pans back into the appliance.

CAUTION! Do not touch the pans during use or immediately after use, as the pans get very hot during and after cooking. Only hold by the handle.

4. Touch the power button. Select the pan to set the cooking process.
5. Select a preset function or set the time and temperature manually for the pans one by one. Then touch the start buttons to start cooking.
6. For cooking some ingredients, it may require turning the contents in the pans or adding small quantity of oil in the cooking ingredients during the cooking process to ensure even cooking and avoid charring of ingredients positioned rear. When this is needed, you can pull out the pan. The appliance will stop heating automatically. After turning or adding oil, place the pan back into the appliance to resume cooking.

NOTE: You may slide out the pan to check at any time during the cooking process. The appliance will pause when the pan is taken out. The appliance will continue the cooking process if the pan is slide in and it will power on again.

7. You can reset the time and temperature setting during the cooking process if required.
8. When you hear the “beep-beep” sound, the set time is elapsed, and the cooking cycle is completed. The appliance is now in standby mode.
9. Check if the ingredients are cooked to your satisfaction. If not, set the time for a few more minutes until the ingredients are cooked to your satisfaction.
10. Remove the pan from the appliance. Only hold by the handle as other surfaces will be hot. Place the pan on a flat, firm, and **heat-resistant surface**. During the cooking process, oil from food will drip and be collected on the bottom of the pan. This can be cleaned at the end of the cooking process when the pan cools down.

11. After using your appliance, remove the plug from the power outlet socket immediately and allow the appliance to cool down completely.

CAUTION!

Beware of escaping steam from the pan, as there is a danger of scalding.

Do not turn the pan with ingredients upside down when tipping the contents onto a dish. Excess oil may have collected in the pan, it could drip out and cause scalding.

IMPORTANT! NEVER LEAVE THE UNIT UNATTENDED WHEN IN USE.

Tips:

1. Smaller ingredients usually require a shorter cooking time than larger ingredients.
2. A larger amount of ingredients will require a longer cooking time.
3. Turning smaller ingredients halfway during the cooking process will provide better cooking results and can help prevent unevenly fried ingredients.
5. To remove large individual or delicate ingredients from the pan, do not tip them out. Pick them up with a pair of tongs.
6. Do not prepare extremely greasy ingredients such as sausages in the air fryer.
7. Snacks that can be prepared in an oven can also be prepared in the fryer.
8. Place a baking tin or oven dish in the air fryer pan if you want to bake a cake/quiche or if you want to fry fragile ingredients or filled ingredients.
9. For best results with home-made chips, soak the cut chips in water for 30 minutes to remove excess starch. Dry on kitchen paper and toss in 1/2 tablespoon of olive oil (or lightly spray with olive oil spray) until the chips are coated.
10. For a crispy home-made coating, mix fine breadcrumbs with a tablespoon of olive oil.
11. Pre-packed snacks like bread crumbed fish or chicken drumsticks only need to be coated lightly with olive oil.

SETTINGS

To assist with selection of cooking times and maximum pan volume for specific ingredients, refer to the COOKING MANUAL section below.

NOTE: Please keep in mind that the cooking manual is indicative and for your reference only. Variation in size, shapes and brands may require an increase or decrease of cooking time and temperature setting to achieve the desired and best cooking outcome.

This type of heating technology reheats the air inside the appliance instantly, so pulling the pan briefly out of the appliance to toss/turn ingredients during cooking will barely disturb the process.

COOKING MANUAL

Category	Food	Amount (g)	Time (min.)	Temperature (°C)	Toss needed	Extra information
Potato & chips	Thin frozen chips	200-500	20-25	220	√	
	Thick frozen chips	200-500	20-30	220	√	
	Potato gratin	100-500	20-30	220	√	
Meat & Poultry	Steak	100-400	12-25	180		
	Pork chops	200-500	12-25	180		
	Sausage roll	200-500	20-25	220		
	Drumsticks	200-600	20-30	220		
	Chicken breast	200-600	20-30	220		
Snacks	Spring rolls	100-400	10-15	200	√	Use oven-ready
	Frozen chicken nuggets	100-500	10-15	200	√	Use oven-ready
	Frozen bread crumbed cheese snacks	200-500	10-12	180		Use oven-ready
Baking	Cake	100-200	25	160		Use baking tin
	Pizza	100-200	25	180		

TROUBLESHOOTING

Problem	Possible cause	Solution
The fryer doesn't work.	The appliance is not connected to mains power outlet socket.	Connect the appliance into a mains power outlet socket.
The ingredients fried in the fryer are not done.	The amount of ingredients in the pan is too high.	Place smaller batches of ingredients in the pan. Smaller batches are fried more evenly.
	The set temperature is too low.	Set the temperature to the required temperature setting (refer to the above cooking manual).
	The preparation time is too short.	Set the timer to the required preparation time.
The ingredients are fried unevenly in the fryer.	Certain types of ingredients need to be tossed/turned halfway during the cooking process.	Ingredients that lie on top of or across each other (e.g. fries) need to be tossed/turned halfway during the cooking process (refer to the cooking manual).
Fried snacks are not crispy when they come out of the fryer	You used a type of snacks meant to be prepared in a traditional deep fryer.	Use oven snacks or lightly brush some oil onto the snacks for a crisper result.
Can't slide the pan into the appliance properly	There are too many ingredients in the pan.	Do not fill too much food in the pan.
	The pan is not placed in the pan properly.	Push the pan down into the pan slot until you hear a 'click'.
White smoke comes out from the appliance.	You are preparing greasy ingredients.	When you fry greasy ingredients in the fryer, a large amount of oil will leak into the pan. The oil produces white smoke, and the pan may heat up more than usual. This does not affect the appliance or the cooking result.
	The pan still contains grease residues from previous use.	White smoke is caused by grease heating up in the pan. Make sure you clean the pan properly after each use.
Fresh chips are fried unevenly in the fryer.	You did not use the right potato type.	Use fresh potatoes and make sure that they stay firm during frying.
	You did not rinse the potato chips properly before you fried them.	Rinse the potato chips properly to remove starch from the outside of the fries.
Fresh chips are not crispy when they come out of the fryer	The crispiness of the chips depends on the amount of oil and water in the fries.	Make sure to dry the potato chips properly before adding the oil.
		Cut the potato chips into smaller pieces for a crispier result.
		Add (sprinkle) slightly more oil for a crisper result.

CLEANING AND STORAGE

1. Remove the supply cord plug from mains power outlet socket and allow the appliance to cool down completely before cleaning. Clean it after every use.

NOTE: Remove the pan to let the air fryer cool down faster.

CAUTION! Do not immerse the housing of the appliance in water or any other liquids when cleaning.

Do not touch hot surfaces.

Do not use harsh abrasives, sharp objects, caustic cleaners or oven cleaners when cleaning this appliance.

2. Wipe the outside of the appliance with a moist soft cloth.
3. Clean the pan and **crisper plate** with hot water and use a non-abrasive sponge with dish-washing liquid. The pan and **crisper plate** are dishwasher safe.

Tip: If dirt is stuck to the **crisper plate** or the bottom of the pan, fill the pan with hot water and some dish-washing liquid. Leave it in the pan to soak for about 10 minutes.

4. Clean the inside of the appliance with a slightly dampened cloth and polish it with a soft dry cloth. If required, lightly brush the heating element to remove any attached food residue.
5. Make sure all parts are clean and dry before storing or using it again.
6. Store the air fryer in a safe, cool, dry place. Do not place any objects on top of the air fryer during storage as this may damage the appliance. Keep it away from children.

TECHNICAL SPECIFICATION

Voltage: 220-240V~ 50-60Hz

Power: 2200W

12 Month Warranty

Thank you for your purchase.

Your new product is warranted to be free from defects in materials and workmanship for the period stated above, from the date of purchase, provided that the product is used in accordance with accompanying recommendations or instructions where provided. This warranty is in addition to your rights under the Australian Consumer Law.

For New Zealand customers, this warranty is in addition to statutory rights observed under New Zealand legislation.

We will provide you with your choice of a refund, repair (where possible) or exchange (availability dependent) for this product if it becomes defective within the warranty period. The business will bear the reasonable expense of claiming the warranty.

This warranty will no longer apply where the defect is a result of alteration, accident, misuse, abuse or neglect.

Please retain your receipt as proof of purchase and contact our Customer Service Centre as listed below, for the entity you purchased this product from, for any difficulties with your product. Warranty claims and claims for expense incurred in returning this product can be addressed to the respective Customer Service Centre.

Our goods come with guarantees that cannot be excluded under the Australian Consumer Law. You are entitled to a replacement or refund for a major failure and compensation for any other reasonably foreseeable loss or damage. You are also entitled to have the goods repaired or replaced if the goods fail to be of acceptable quality and the failure does not amount to a major failure.

Contact for Kmart purchases	Contact for Target purchases
Kmart Australia Ltd. C/- Customer Service Centre L2/ 1 MIDDLE ROAD, CHADSTONE VIC 3148 AUSTRALIA Customer Service: 1800 124 125 (Australia) or 0800 945 995 (New Zealand) or via Customer Help at kmart.com.au	Target Australia Pty Ltd C/- Customer Service Centre L2/ 1 MIDDLE ROAD, CHADSTONE VIC 3148 AUSTRALIA Customer Service: 1300 753 567 or via Customer Help at target.com.au/help/contact-us