

anko

Mini Vacuum Cleaner

8050

User Manual



**PLEASE READ AND SAVE THESE
INSTRUCTIONS FOR FUTURE REFERENCE**

IMPORTANT SAFEGUARDS

When using any electrical product, always follow these basic safety precautions:



READ ALL INSTRUCTIONS BEFORE USE.

- Please read all the instructions carefully before using this product.
- This appliance is not intended for use by persons (including children) with reduced physical, sensory or mental capabilities, or lack of experience and knowledge, unless they have been given supervision or instruction concerning use of the appliance by a person responsible for their safety.
- Children should be supervised to ensure that they do not play with the appliance.
- This appliance must be always used in accordance with the user instructions supplied with the product and must not be used for other purposes.
- Switch OFF the appliance before changing batteries.
- For cleaning, please refer to “CLEANING AND STORAGE” section.

CAUTION!

- This product is for household use only and not designed for commercial use.
- Do not expose the product to high temperatures, strong magnetic fields, near flammable and explosive gases (such as natural gas, methane, etc.) to avoid accidents such as abnormal operations or fire.
- Cleaning and user maintenance shall not be done by children without supervision.

WARNING: Keep the appliance dry.

- Non-rechargeable batteries are not to be recharged.
- Batteries are to be inserted with the correct polarity.
- Exhausted batteries are to be removed from the appliance and safely disposed of.
- If the appliance is stored unused for a long period, the batteries should be removed.
- The supply terminals are not to be short-circuited.
- Type of Battery: 1.5V AA
- Open the cover, insert the battery with correct polarity, then close the cover correctly. The cover can only be closed completely when cover is put in correct position.

**SAVE THESE INSTRUCTIONS
FOR FUTURE REFERENCE**

KNOW YOUR MINI VACUUM CLEANER

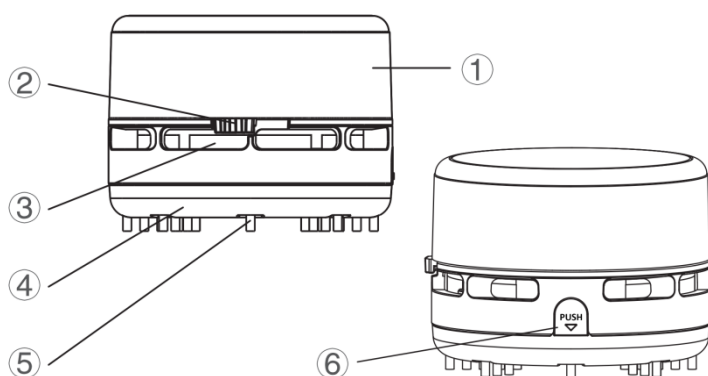

1. Top cover
2. On/Off switch
3. Air outlet
4. Bottom cover (dustbin)
5. Brush
6. Bottom cover release button

IMPORTANT!

Please make sure that your appliance is received with the right components shown above. Check everything carefully before using it. If any parts are missing or damaged, return the product to place of purchase.

When using the appliance for the first time, carefully remove all internal and external packaging and dispose them responsibly.

USE YOUR MINI VACUUM CLEANER

1. Turn counterclockwise to open the top cover.
2. Put 2pcs 1.5V AA batteries into the product, then assemble the top cover.
3. Turn on the appliance and start cleaning.

Note: Allow the appliance to rest 30 minutes after 30 seconds running.

Tips: The brush helps to sweep the stubborn attached stains.

4. Turn off the appliance after cleaning.
5. Push bottom cover release button, take off the bottom cover, use paper or brush to clean the dust.
6. Assemble the bottom cover.

CLEANING AND STORAGE

- Remove the batteries before cleaning or during storage.
- Clean the product regularly to maintain optimal performance and prolong the life of the product.
- Do not use a steel ball, abrasive cleaners or corrosive liquid (such as gasoline, acetone) to clean the product.
- Rinsing the top cover, bottom cover with water, dry thoroughly.
- The main unit can be wiped with a slightly damp cloth. Do not rinse, soak or spray water or other liquids into the product to avoid damage to the appliance.
- Ensure the product is clean and dry before storage.
- Store the product indoors in a cool and dry location.

BATTERY DISPOSAL

Batteries contain substances harmful to our environment. Do not dispose of the appliance with batteries inside. Remove the batteries and dispose them at your local council recycling point for environmental protection.

TECHNICAL SPECIFICATION

Input: 3Vd.c. (2 x 1.5V AA Batteries)

Operating temperature: 0°C to 35°C

Storage temperature: -10°C to 45°C

12 Month Warranty

Thank you for your purchase.

Your new product is warranted to be free from defects in materials and workmanship for the period stated above, from the date of purchase, provided that the product is used in accordance with accompanying recommendations or instructions where provided. This warranty is in addition to your rights under the Australian Consumer Law.

For New Zealand customers, this warranty is in addition to statutory rights observed under New Zealand legislation.

We will provide you with your choice of a refund, repair (where possible) or exchange (availability dependent) for this product if it becomes defective within the warranty period. The business will bear the reasonable expense of claiming the warranty.

This warranty will no longer apply where the defect is a result of alteration, accident, misuse, abuse or neglect.

Please retain your receipt as proof of purchase and contact our Customer Service Centre as listed below, for the entity you purchased this product from, for any difficulties with your product. Warranty claims and claims for expense incurred in returning this product can be addressed to the respective Customer Service Centre.

Our goods come with guarantees that cannot be excluded under the Australian Consumer Law. You are entitled to a replacement or refund for a major failure and compensation for any other reasonably foreseeable loss or damage. You are also entitled to have the goods repaired or replaced if the goods fail to be of acceptable quality and the failure does not amount to a major failure.

Contact for Kmart purchases	Contact for Target purchases
Kmart Australia Ltd. C/- Customer Service Centre L2/ 1 Middle Road, Chadstone Vic 3148 Australia Customer Service: 1800 124 125 (Australia) or 0800 945 995 (New Zealand) or via Customer Help at kmart.com.au	Target Australia Pty Ltd C/- Customer Service Centre L2/ 1 Middle Road, Chadstone Vic 3148 Australia Customer Service: 1300 753 567 or via Customer Help at target.com.au/help/contact-us