

Cleaning & Maintenance:

- 1) Turn the appliance off before you start cleaning it.
- 2) Do not immerse the appliance in water. Clean the appliance surface with a dry cloth or with a cloth moistened with water.
- 3) Do not use any lubricant, detergent, polishing agents, alcohol, steel wool, abrasive cleansers, chemicals or corrosive liquids on this appliance.

Battery and appliance disposal:

1. This appliance has a lithium battery. Batteries contain substances harmful to our environment, please do not dispose of the appliance containing batteries with the normal household waste, instead hand it over to an official recycling point.

2. Trouble Shooting

Problem	Possible Cause	Solution
LED Light is not bright enough or it does not turn on	The battery is running low or is out of power	Charge the appliance as guided

anko

OSLO GLASS PORTABLE RECHARGEABLE LAMP
K: 43697304 | T: 72411544
SLR-25763

INSTRUCTION MANUAL

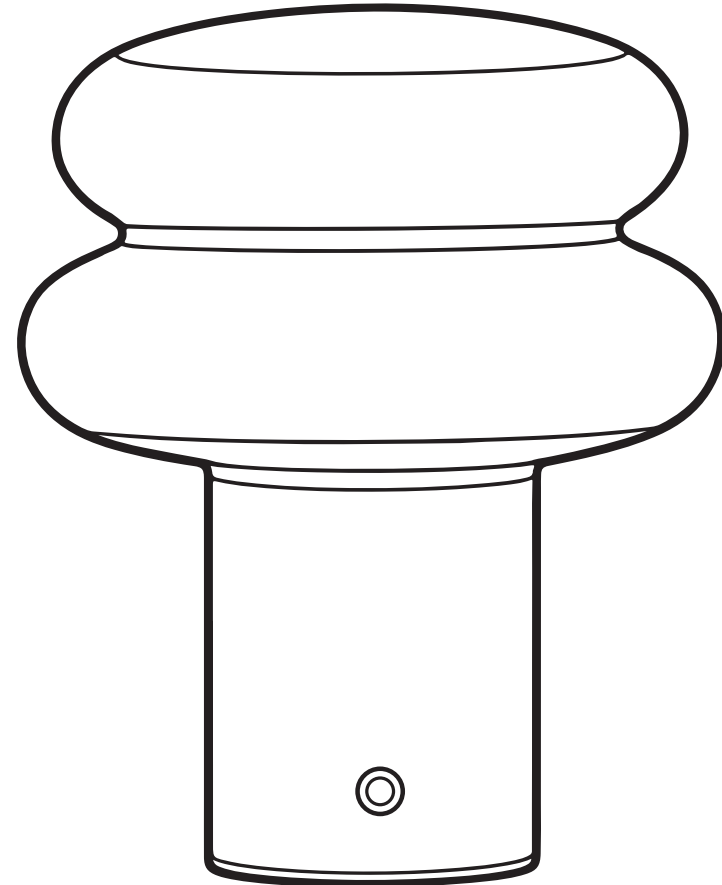

Safety Instructions:

To ensure proper operation of this appliance, please read this instruction manual carefully before you use the appliance and save it for further reference.

⚠ WARNING

- Check the appliance before you use it, do not use the appliance if it has any crack, gap or any other damage.
- Do not attempt to repair, disassemble, or modify the appliance by yourself to avoid accidents.
- The light source of this luminaire is not replaceable; when the light source reaches its end of life the whole luminaire shall be replaced.
- For indoor use only.

⚠ CAUTION

- This appliance has a lithium battery. Do not place or store the appliance for long periods of time in a hot or humid environment. If you do not intend to use the appliance for a long time, store the appliance after fully charged.
- This appliance contains rechargeable battery and LED lights that are non-replaceable.
- Ensure charging adapter used is compatible with a 5V DC SELV 1A, 5W rating.
- Only charge the product with an approved and suitable USB charger that complies with the requirements of the relevant standards.
- Use provided charging cable to charge the product only.

Specifications:

- Charging Voltage / Current: 5V $\overline{\text{---}}$ / 1000mA 5W
- Type of Battery: Li-ion 3.7V 2000mAh
- Ta: 25°C

Product Description:

① ON/OFF touch switch

② Charging port

③ USB cable

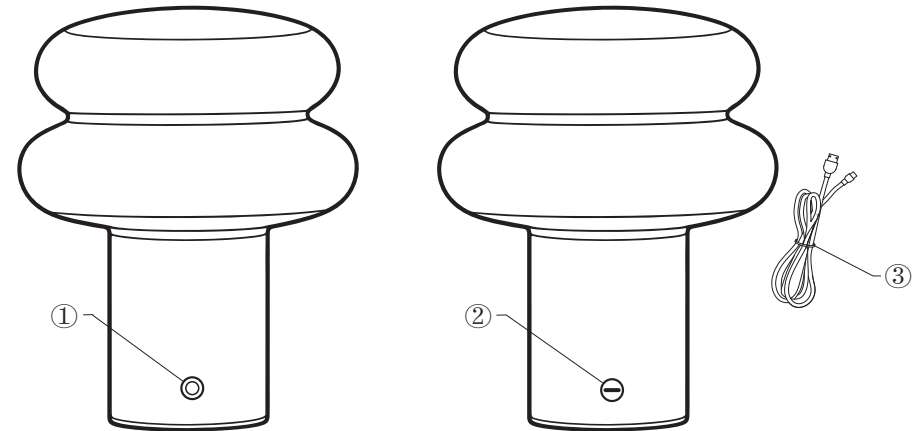

Using the Appliance:

For better use experience, please read below instructions carefully:

1. Use provided charging cable to fully charge the unit before use.
2. This appliance needs to be charged if the light ray is not bright enough. Please use 5V DC SELV 1A 5W adaptor(not included) to charge.
3. Charging the appliance takes about 3 hours, and it can be used continuously for more than 5 hours for the most bright status.
4. The charging indicator light (under the charging port) will be red while the table lamp is charging and after being fully charged, the indicator light will be green.
5. Touch the switch ① to turn on the light source, with three brightness levels to choose. Touch the 4th time to turn off the light.

12 Month Warranty

Thank you for your purchase.

Your new product is warranted to be free from defects in materials and workmanship for the period stated above, from the date of purchase, provided that the product is used in accordance with accompanying recommendations or instructions where provided. This warranty is in addition to your rights under the Australian Consumer Law.

For New Zealand customers, this warranty is in addition to statutory rights observed under New Zealand legislation.

We will provide you with your choice of a refund, repair (where possible) or exchange (availability dependent) for this product if it becomes defective within the warranty period. The business will bear the reasonable expense of claiming the warranty.

This warranty will no longer apply where the defect is a result of alteration, accident, misuse, abuse or neglect.

Please retain your receipt as proof of purchase and contact our Customer Service Centre as listed below, for the entity you purchased this product from, for any difficulties with your product. Warranty claims and claims for expense incurred in returning this product can be addressed to the respective Customer Service Centre.

Our goods come with guarantees that cannot be excluded under the Australian Consumer Law. You are entitled to a replacement or refund for a major failure and compensation for any other reasonably foreseeable loss or damage. You are also entitled to have the goods repaired or replaced if the goods fail to be of acceptable quality and the failure does not amount to a major failure.

MADE IN CHINA

CUSTOMER SERVICE:

KMART AU: 1800 124 125

KMART NZ: 0800 945 995

TARGET AU: 1300 753 567