

# anko

**Air Fryer**

**AF661**

**User Manual**



**PLEASE READ AND SAVE THESE  
INSTRUCTIONS FOR FUTURE REFERENCE**

## IMPORTANT SAFEGUARDS

When using any electrical product, always follow these basic safety precautions:



### **READ ALL INSTRUCTIONS BEFORE USE.**

1. Always turn the appliance OFF and disconnect from mains power when not in use, before attempting to move the appliance and before cleaning or storing.
2. Never immerse the main unit and power plug and cord in water or any other liquid, nor rinse them under the tap.
3. To prevent electric shock and short-circuit, avoid any liquid from entering the appliance.
4. If the appliance or power plug and cord is damaged, it must be replaced by a qualified electrician to avoid a hazard, or the product must be disposed of.
5. This appliance is not intended for use by persons (including children) with reduced physical, sensory or mental capabilities, or lack of experience and knowledge, unless they have been given supervision or instructions concerning use of the appliance by a person responsible for their safety.
6. Children should be supervised to ensure that they do not play with the appliance.
7. Do not leave the appliance unattended when in use or when connected to mains power.
8. **CAUTION!** surfaces may become hot during use. This is normal.
9. Do not let the cord touch hot surfaces, become knotted or hang from the edge of bench tops.
10. Do not place this appliance on or near a hot gas or electric burner, or where it could touch a heated oven.
11. Keep the unit clear of walls, curtains, and other heat sensitive materials (leave a minimum clearance of 20cm from the sides and back of the appliance).

**WARNING! Do not place unit under shelving, cabinets or flammable materials when in use.**

12. Never overfill ingredients above the Max level mark in the pan. Keep all ingredients inside the pan and do not overfill beyond the pan to prevent any direct contact with the heating element.
13. Do not move the appliance when in use.
14. Do not cover the air inlet or the air outlet when the appliance is working.
15. Do not touch the inside of the appliance while it is operating or immediately after use.
16. Do not use the appliance for any other purpose than described in this manual.
17. Do not place anything on top of the appliance when in use and when stored.
18. Before connecting the appliance to the power supply, check that the voltage indicated on the appliance corresponds with the voltage in your home. If this is not the case, DO NOT use the appliance.
19. This appliance is not intended to be operated by means of an external timer or a separate remote-control system.
20. The use of accessories not recommended by the appliance manufacturer may cause serious injury and/or damage to the appliance.

21. This appliance is for household use only, not for commercial use. Do not use this appliance for other than its intended use. Do not use in moving vehicles or boats. Do not use outdoors.
22. This appliance is intended to be used indoors in household and similar applications such as:
  - staff kitchen areas in shops offices and other working environment,
  - farmhouses,
  - by clients in hotels, motels and other residential type environments,
  - bed and breakfast type environments.
23. During hot air frying, hot steam is released through the air outlet. To avoid scalding, keep a safe distance from steam and the air outlet.
24. Be careful of hot steam and air when you remove the pan from the appliance.



**CAUTION! Hot surfaces. Do not touch the pan during use or immediately after use, the pan gets very hot. Only hold by the handle.**

25. For cleaning, please refer to CLEANING AND STORAGE section.

### **IMPORTANT!**

26. Use the appliance only on a dry, level, stable, and heat-resistant surface only, away from any edges.
27. Do not use the appliance under overhead cabinets or presses. The hot steam may cause damage to glass splashback, cabinets or presses.
28. This appliance must be connected to a three-point power outlet socket connected to Earth. If unsure, check with an electrician.
29. **FIRE HAZARD! DO NOT fill the pan with oil.**
30. Always unplug the power cord from mains power outlet socket when the appliance is not in use.
31. Always allow the appliance to cool down completely before cleaning.

**WARNING! To prevent risk of severe personal injury and/or property damage, use extreme caution when cooking.**

**SAVE THESE INSTRUCTIONS  
FOR HOUSEHOLD USE ONLY**

# KNOW YOUR AIR FRYER

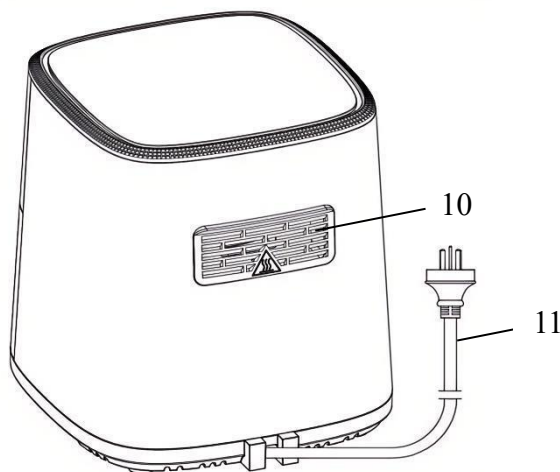
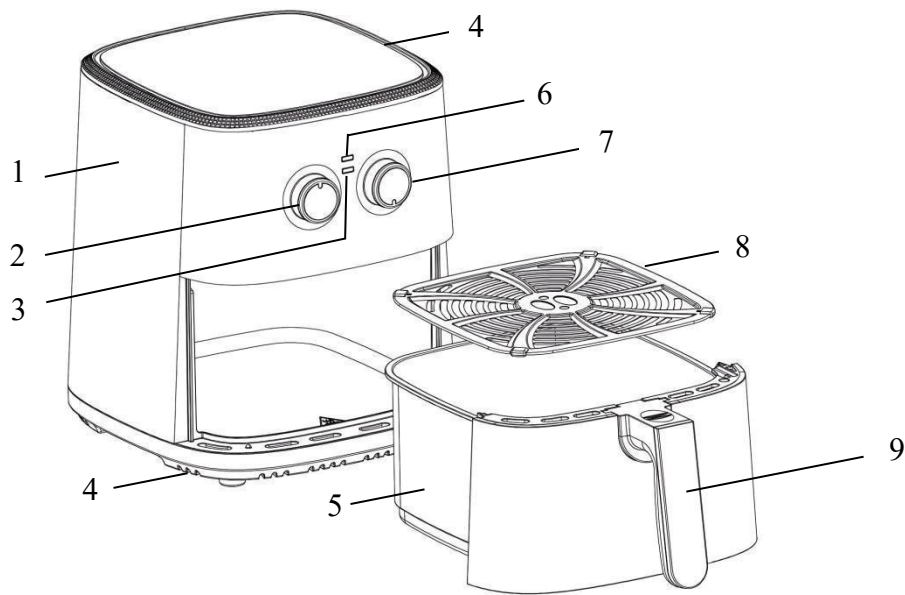

1. Main unit
2. Time knob
3. Green heating indicator
4. Air inlet
5. Food pan
6. Orange working indicator
7. Temperature knob
8. Crisper plate
9. Handle
10. Hot air outlet
11. Power plug & cord

## IMPORTANT!

- Please make sure that your appliance is received with the right components shown above. Check everything carefully before using. If any parts are missing or damaged, return the product to respective customer service centre.
- When using the appliance for the first time, carefully remove all packaging and dispose of them responsibly.

## INTRODUCTION

- The air fryer provides an easy and healthier way of cooking your favorite foods. By applying rapid air circulation from all directions, it can cook a variety of dishes without adding any oil or cook with mist of oil.

# HOW TO USE YOUR AIR FRYER

## Preparing for use

1. Place the appliance on a stable, horizontal, flat and heat-resistant surface.

**IMPORTANT! To prevent heat damage, place the appliance on a heat-resistant surface only. Not recommended to use directly on laminated/vinyl bench top. To prevent heat damage to the bench top, placing the air fryer on an insulated heat pad is recommended.**

2. Clean the appliance according to the instructions in CLEANING AND STORAGE section. Dry thoroughly.
3. Put the crisper plate in the pan and place the pan on a flat surface.

## Using the appliance

1. Make sure both temperature & time knobs are set at position “0”.
2. Connect the supply cord plug into a mains power outlet socket. The appliance is now in standby mode.
3. Place the ingredients into the pan.

**IMPORTANT! Do not fill food beyond the MAX mark in the pan.**

**Do not fill more than 2.2kg food in the pan.**

4. Slide the pan back into the appliance.

**CAUTION! Do not touch the pan during use or immediately after use, as the pan gets very hot. Only hold by the handle.**

5. Rotate the temperature and time knob to set your desired temperature and time for the ingredients. The green heating indicator and orange working indicator light up, and the appliance starts cooking.

There is a cooking manual in this booklet for your reference. You can also simply refer to the suggested cooking temperature printed on the appliance as follows:

Icons	Preset	Time	Temperature
	Chips	15-20 minutes	200°C
	Chops	20-25 minutes	180°C
	Prawns	15-20 minutes	160°C
	Baking	20-30 minutes	160°C
	Drumsticks	20-25 minutes	200°C
	Steaks	10-20 minutes	180°C
	Fish	15-20 minutes	160°C

Notice: The temperature and time in the manual are for reference only. You can adjust the time and temperature according to the volumes of the ingredients placed in the pan.

Tips: Before cooking the food, it is better to preheat the appliance without food in the pan by setting the timer to 3 minutes with temperature set at 180°C.

6. For cooking of some ingredients, it may require turning the contents in the pan or add small quantity oil in the cooking ingredients during the cooking process to ensure even cooking and avoid charring of ingredients positioned at the top of the pan. When this is needed, you can pull out the pan, the appliance will stop heating automatically. After turning or spraying small amount of oil, place the pan back into the appliance to resume cooking.

Notice:

The timer is not stopped when the pan and pan is pulled out. You can adjust the time and temperature setting at any time during the cooking process.

The green heating light will go OFF when the air inside reaches the set temperature. And it will light up again when the air temperature inside is lower than set.

7. When you hear the bell, the set time is elapsed, and the cooking cycle is completed. The appliance is now in standby mode with both indicator lights off.
8. Check if the ingredients are cooked to your satisfaction. If not, set the timer for a few more minutes until it is cooked to your satisfaction.
9. Remove the pan from the appliance. **Only hold by the handle as other surfaces will be hot.** Place the pan on a flat, firm, and heat-resistant surface. Tip contents onto a dish.

Notice: During the cooking process, oil from food will drip and be collected on the bottom of the pan. This can be cleaned at the end of the cooking process when the pan cools down.

10. After using your appliance, remove the power plug from the wall socket and allow the appliance to cool down completely.

### **CAUTION!**

- Beware of escaping steam from the pan. Danger of scalding!
- Do not turn the pan with ingredients upside down with the pan attached when tipping the contents onto a dish. Excess hot oil or food residue may have collected in the pan, and it could drip out and cause scalding.

**IMPORTANT! Do not leave the appliance unattended when in use.**

### **Tips**

- Smaller ingredients usually require a shorter cooking time than larger ingredients.
- A larger amount of ingredients will require a longer cooking time.
- Turning smaller ingredients halfway during the cooking process will provide better cooking results and can help prevent unevenly fried ingredients.
- Snacks that can be prepared in an oven can also be prepared in the fryer.
- Place a baking tin or oven dish in the pan if you want to bake a cake/quiche or if you want to fry fragile ingredients or filled ingredients.
- You can also use the air fryer to reheat ingredients. To reheat ingredients, set the temperature to 150°C for up to 10 minutes.
- For best results with home-made chips, soak the cut chips in water for 30 minutes to remove excess starch. Dry on kitchen paper and toss in 1/2 tablespoon of olive oil (or lightly spray with olive oil spray) until the chips are coated.
- For a crispy home-made coating, mix fine breadcrumbs with a tablespoon of olive oil.
- Pre-packed snacks like bread crumbed fish or chicken drumsticks only need to be coated lightly with olive oil.
- You can set the timer for half of the cooking time. When time elapsed and a “click” sound heard, remove the pan from the appliance to toss/turn the ingredients. When placing the pan back in the appliance again, reset the timer for the balance of the cooking time.

## Settings

- To assist with selection of cooking times and maximum pan volumes for specific ingredients, refer to the COOKING MANUAL section.

**Notice: Please keep in mind that the cooking manual is indicative and for your reference only. Variation in size, shapes and brands may require an increase or decrease of cooking time and temperature setting to achieve the desired and best cooking outcome.**

- This type of heating technology reheats the air inside the appliance instantly, so pulling the pan briefly out of the appliance to toss/turn ingredients during cooking will barely disturb the process.

## COOKING MANUAL

Ingredients	Amount (g)	Cooking time (minutes)	Temperature (°C)	Toss/turn needed	Extra information
<b>Chips &amp; potatoes</b>					
Frozen french chips	300-800	12-20	200	√	
Frozen chunky chips or potato wedges	300-800	15-25	200	√	
Home-made french chips	300-800	20-25	180	√	Add 1/2 tbsp of oil
<b>Fresh meat &amp; poultry</b>					
Steak/beef cubes	100-800	15-25	180	√	
Lamb or pork chops	150-600	16-25	180	√	
Mince patties/meat balls	100-650	12-20	180	√	
Chicken wings/drumsticks/thigh /breast	100-900	20-30	180	√	
Chicken thigh	400-1200	30-45	200	√	
<b>Fish and Shrimp</b>					
Fish (fresh)	150-450	12-20	160	√	
Shrimp (fresh)	500	20	160	√	
<b>Snacks</b>					
Spring rolls	100-400	8-10	200	√	Use oven-ready
Frozen chicken nuggets	150-850	18-25	180	√	Use oven-ready
Frozen bread crumbed cheese snacks	100-200	8-10	180	√	Use oven-ready
Sausage roll	100-700	13-18	200	√	
<b>Baking</b>					
Cake	300	30	160		Use baking tin
muffins	300-600	25-30	160		Use baking tin/ramekin
Tarts/souffle	360	20	160		Use baking tin/ramekin

Pizza	500-800	20-25	180		Use pizza pan
-------	---------	-------	-----	--	---------------

## **TROUBLESHOOTING**

<b>Problem</b>	<b>Possible cause</b>	<b>Solution</b>
The fryer doesn't work.	The appliance is not connected to mains power outlet socket.	Connect the appliance into a mains power outlet socket.
The ingredients fried in the fryer are not done.	The amount of ingredients in the pan is too high.	Place smaller batches of ingredients in the pan. Smaller batches are fried more evenly.
	The set temperature is too low.	Set the temperature to the required temperature setting (refer to the above cooking manual).
	The preparation time is too short.	Set the timer to the required preparation time.
The ingredients are fried unevenly in the fryer.	Certain types of ingredients need to be tossed/turned halfway during the cooking process.	Ingredients that lie on top of or across each other (e.g., fries) need to be tossed/turned halfway during the cooking process (refer to the cooking manual).
Fried snacks are not crispy when they come out of the fryer	You used a type of snacks meant to be prepared in a traditional deep fryer.	Use oven snacks or lightly brush some oil onto the snacks for a crisper result.
Can't slide the pan into the appliance properly	There are too many ingredients in the pan.	Do not fill the ingredients over the "MAX" mark in the pan.
White smoke comes out from the appliance	You are preparing greasy ingredients.	When you fry greasy ingredients in the fryer, a large amount of oil will leak into the pan. The oil produces white smoke, and the pan may heat up more than usual. This does not affect the appliance or the end result.
	The pan still contains grease residues from previous use.	White smoke is caused by grease heating up in the pan. Make sure you clean the pan properly after each use.
Fresh chips are fried unevenly in the fryer	You did not use the right potato type.	Use fresh potatoes and make sure that they stay firm during frying.
	You did not rinse the potato chips properly before you fried them.	Rinse the potato chips properly to remove starch from the outside of the fries.
Fresh chips are not crispy when they come out of the fryer	The crispiness of the chips depends on the amount of oil and water in the fries.	Make sure to dry the potato chips properly before adding the oil.
		Cut the potato chips smaller for a crispier result.
		Add slightly more oil for a crisper result.

## CLEANING AND STORAGE

1. Clean the appliance after every use.
2. Remove the power plug and cord from mains power outlet socket and allow the appliance to cool down completely before cleaning.

Notice: Remove the pan to let the air fryer cool down faster.

**CAUTION! Do not immerse the main unit, the power plug and cord in water or any other liquids to clean.**

**Do not touch hot surfaces.**

**Do not use harsh abrasives, sharp objects, caustic cleaners or oven cleaners when cleaning this appliance.**

3. Clean the pan and crisper plate with hot water and use a non-abrasive sponge with dish-washing liquid. The pan and crisper plate are dishwasher safe.

Tips: If dirt is stuck to the pan or the crisper plate, fill the pan with hot water and some dish-washing liquid. Leave it in the pan to soak for about 10 minutes.

4. Clean the inside and outside of the main unit with a slightly dampened cloth and polish it with a soft dry cloth.
5. If necessary, lightly brush the heating element to remove any attached food residue.
6. Make sure all parts are clean and dry before storing or using it again.
7. Store the air fryer in a safe, cool, dry place.

## TECHNICAL SPECIFICATION

Voltage: 220-240V~ 50-60Hz

Power: 1500W

MAX. weight of food **should not exceed 2.2Kg**

## **12 Month Warranty**

Thank you for your purchase.

Your new product is warranted to be free from defects in materials and workmanship for the period stated above, from the date of purchase, provided that the product is used in accordance with accompanying recommendations or instructions where provided. This warranty is in addition to your rights under the Australian Consumer Law.

For New Zealand customers, this warranty is in addition to statutory rights observed under New Zealand legislation.

We will provide you with your choice of a refund, repair (where possible) or exchange (availability dependent) for this product if it becomes defective within the warranty period. The business will bear the reasonable expense of claiming the warranty.

This warranty will no longer apply where the defect is a result of alteration, accident, misuse, abuse or neglect.

Please retain your receipt as proof of purchase and contact our Customer Service Centre as listed below, for the entity you purchased this product from, for any difficulties with your product. Warranty claims and claims for expense incurred in returning this product can be addressed to the respective Customer Service Centre.

Our goods come with guarantees that cannot be excluded under the Australian Consumer Law. You are entitled to a replacement or refund for a major failure and compensation for any other reasonably foreseeable loss or damage. You are also entitled to have the goods repaired or replaced if the goods fail to be of acceptable quality and the failure does not amount to a major failure.

<b>Contact for Kmart purchases</b>	<b>Contact for Target purchases</b>
Kmart Australia Ltd. C/- Customer Service Centre L2/ 1 Middle Road, Chadstone Vic 3148 Australia Customer Service: 1800 124 125 (Australia) or 0800 945 995 (New Zealand) or via Customer Help at <a href="http://kmart.com.au">kmart.com.au</a>	Target Australia Pty Ltd C/- Customer Service Centre L2/ 1 Middle Road, Chadstone Vic 3148 Australia Customer Service: 1300 753 567 or via Customer Help at <a href="http://target.com.au/help/contact-us">target.com.au/help/contact-us</a>