

anko

Automated Cat Litter Box

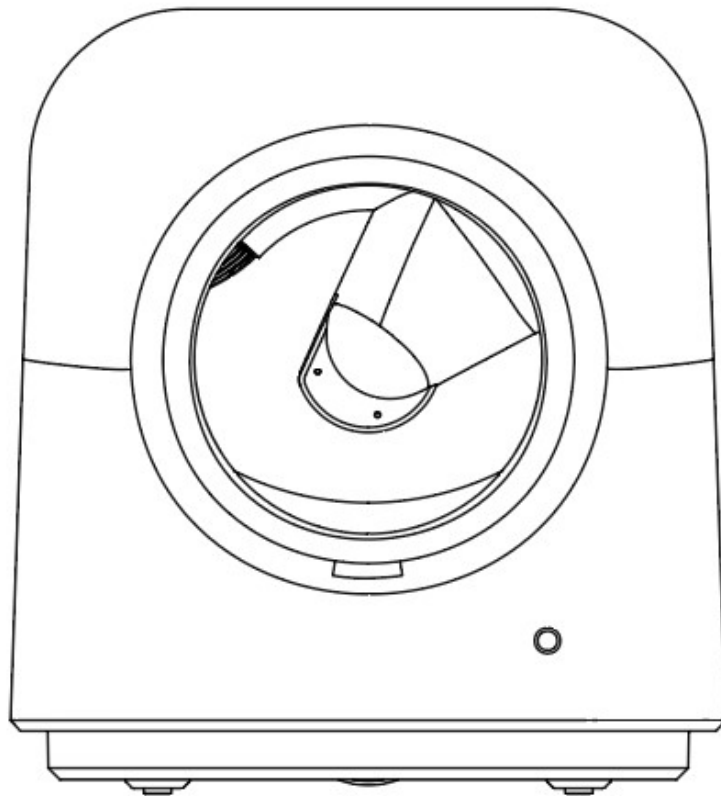

MADE IN CHINA

Product Specifications:

Product Name: Automated Cat Litter Box
Size: 545 x 545 x 595 (H) mm
Input voltage: AC100-240V,50Hz/60Hz
Output voltage: DC 12V 2A
Weight: 13.5KG
Toileting Space : 60L
Waste Bin Capacity : 5.9L
Target Cats : Weight 1.5-15 kg and age > 6 months
Applicable Litter: Clumping cat litter,bentonite and tofu cat litter (length < 1.2 cm)

Packing List :

Automated Cat Litter Box x 1	Instructions Manual x 1
Adaptor x 1	Garbage bag x 1 roll (20pcs)
Deodoriser x 1	Sifting mat x 1

Attention:

Before using this product, please read the instructions carefully, and follow the guide accordingly.



Warning:

- This appliance is not intended for use by persons (including children) with reduced physical, sensory or mental capabilities, or lack of experience and knowledge, unless they have been given supervision or instruction concerning use of the appliance by a person responsible for their safety.
- If children use this device, ensure that they operate it under adult supervision. Children should be supervised to ensure that they do not play with the appliance.
- The appliance is only to be used with the power supply unit provided.
- Except for professional maintenance personnel, no one is allowed to repair this product without authorisation to avoid various unexpected injuries.
- The maximum height of cat litter added must not exceed the "MAX" marking line.
- It is recommended to use bentonite cat litter and tofu cat litter (with a particle length <1.2 cm).
- This product cannot be washed with water; only the surface can be wiped, and it must be dried before reuse.
- Be sure to place the machine on a flat and hard surface (do not place it on soft surfaces such as carpets or areas with height differences), otherwise, it will affect the operation of the device.
- Do not use this product for a long time in a strong magnetic field environment, as this may cause equipment malfunctions.

Product parts information:

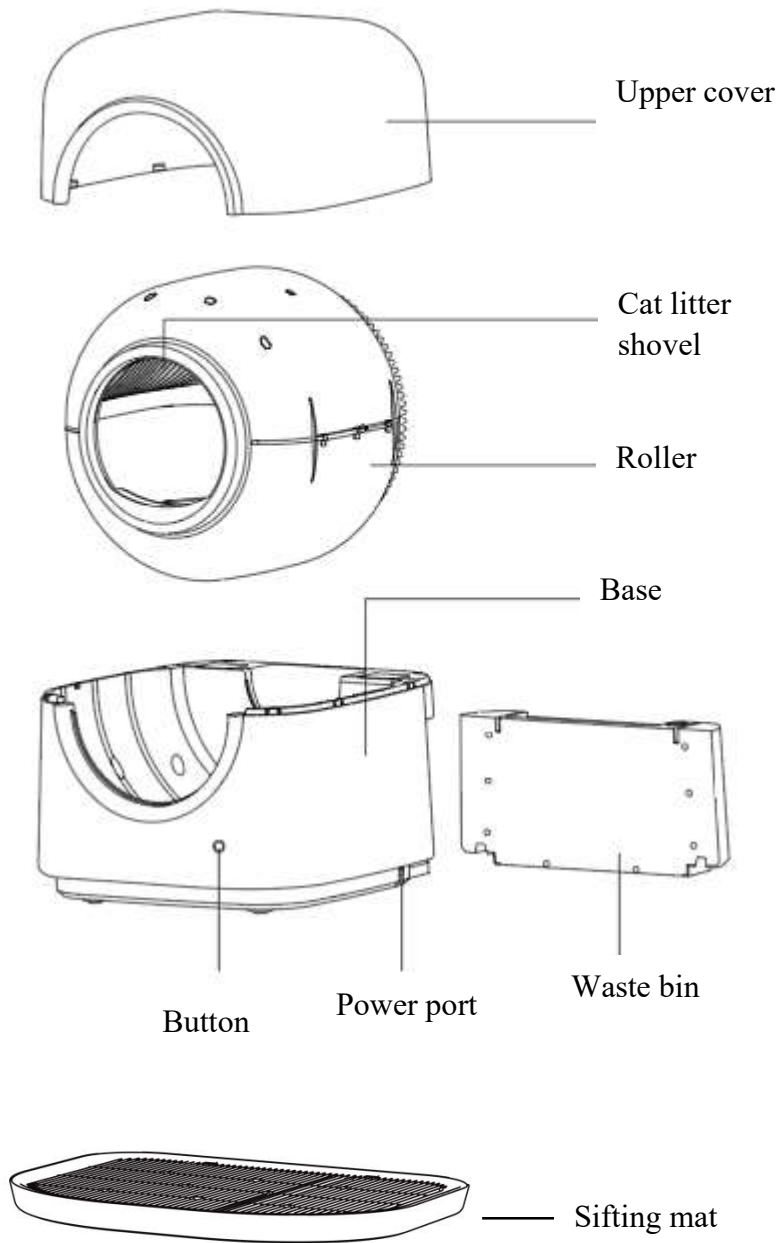

Mode Setting:

- **Power On / Standby Mode:**

After plugging in the power and turning on the machine, it starts up and enters standby mode (the green light stays on). If it is the first time launching the app, a prompt for network pairing will appear (the green light flashes quickly). Once network pairing is completed, the green light will stay on to indicate entry into standby mode.

- **Long Press**

Press and hold the button for 10 seconds to reset the settings, and the machine will enter network pairing mode. Users must follow the network connection guidelines to add the device to the app.

- **Single Press**

Press the button once to manually activate the cleaning mode once.

Cleaning Mode: Cleans feces and large clumped cat litter in the roller into the waste bin.

- **Double Press**

Double-press the button to activate the sand dumping mode once.

Sand Dumping Mode: Cleans all waste sand in the roller into the waste bin.

- **Button Light Control**

If you need to turn off the button light, you can enter the app's "Settings - Indicator Light" to disable it.

How to use :

Step 1:

Remove the waste bin from the left or right side of the machine.

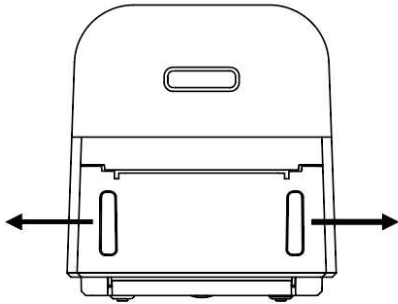

Step 2:

Install the garbage bag and deodoriser. Follow the direction shown in the diagram. Remove the lid of the waste bin, tuck the edge of the garbage bag into the groove of the waste bin, then reinstall the lid to secure the bag. Remove the outer packaging of the deodoriser and insert it into the groove of the lid .

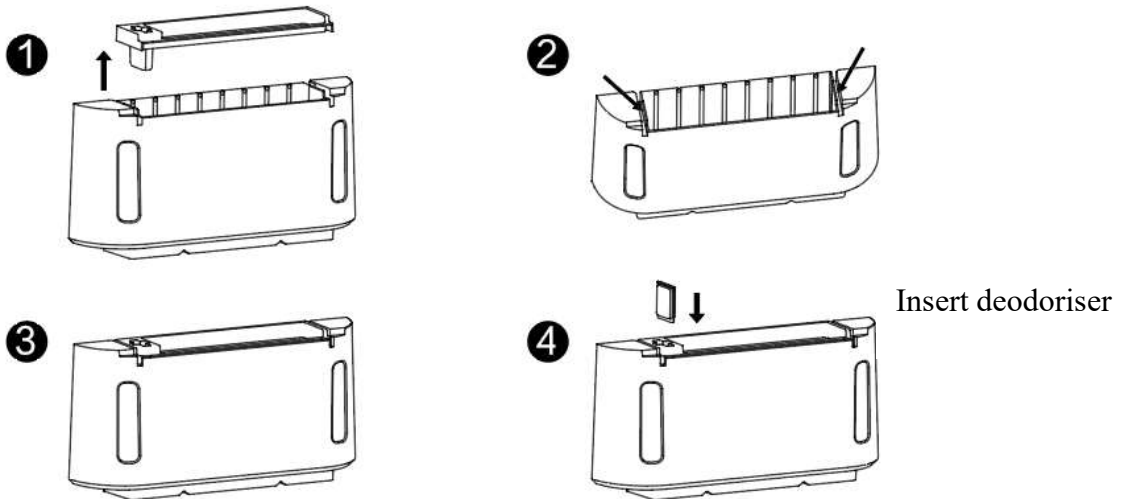

Step 3:

Reinstall the waste bin into the machine from the left or right side.

Step 4:

Connect the power port and plug in the power supply.

When the machine is turned on for the first time, it will automatically start and roll to find a balanced working position. This process may take several minutes.

When the machine is turned on for the first time, it enters network pairing mode, and the green light will flash rapidly, waiting for the user to connect to the network and add the device via the APP.

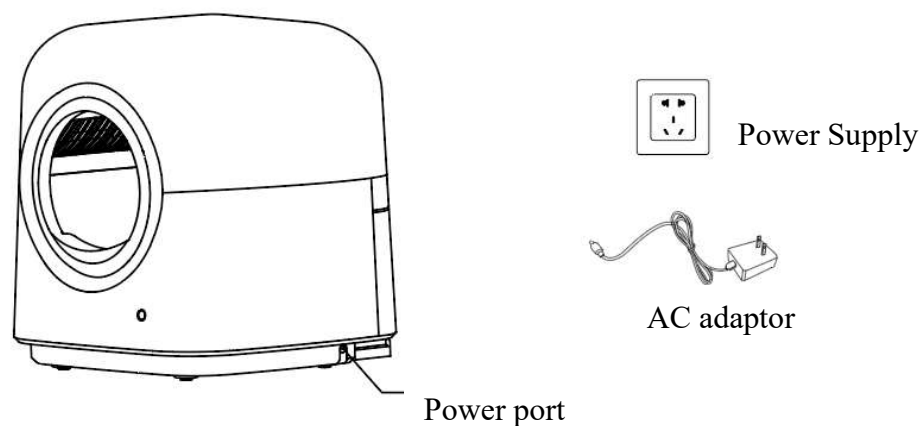

Step 5:

It is recommended to add cat litter up to the "MAX" marking line (a sticker inside the roller). Do not add cat litter beyond this line, as excessive litter will shorten the machine's service life. After adding litter, the machine will display a steady blue light for approximately 5 minutes, then switch to a green light and automatically level the added litter. (Applicable cat litter: All clumping cat litter, bentonite, tofu cat litter (particle length < 1.2cm).

Step 6:

Place the sifting mat in front of the machine. The function of the mat is to prevent cat litter from scattering around the house.

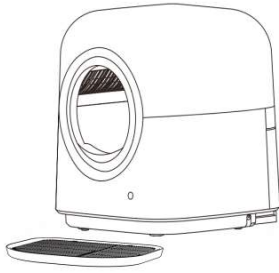

Step 7:

The machine can be used standalone or connected to the network.

Manual operation: After powering on and adding cat litter, the machine automatically enters standalone mode (only the cleaning mode is available).

App operation: Connect to the network according to the following instructions and control the machine via the APP.

Network Setting:

1. Search for and download the "TUYA SMART" APP in the Apple Store or Google Play, then register and log in to your account.

Log in with Password



China Unicom provides verification services

Quick Login

Try as Guest

2. Press the button and hold on for 10s, the green lights flash quickly and the machine will enter network pairing mode. Turn on your phone's Bluetooth and WiFi functions, click the "+" icon in the upper right corner of the APP, and select "Add Device".

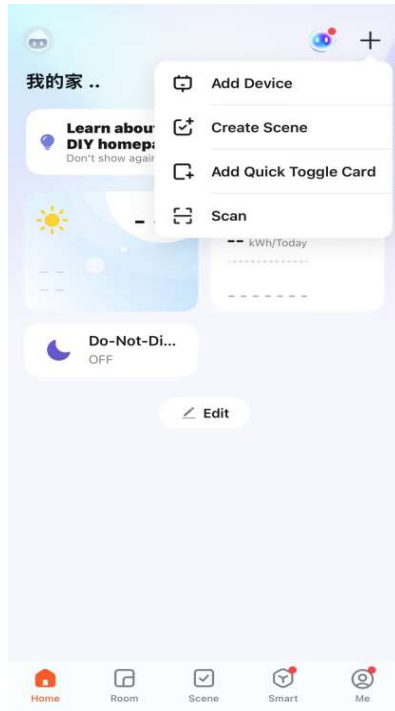

3. After the APP searches for the device, click "Add" (ensure the machine is in pairing mode with the green light flashing rapidly).

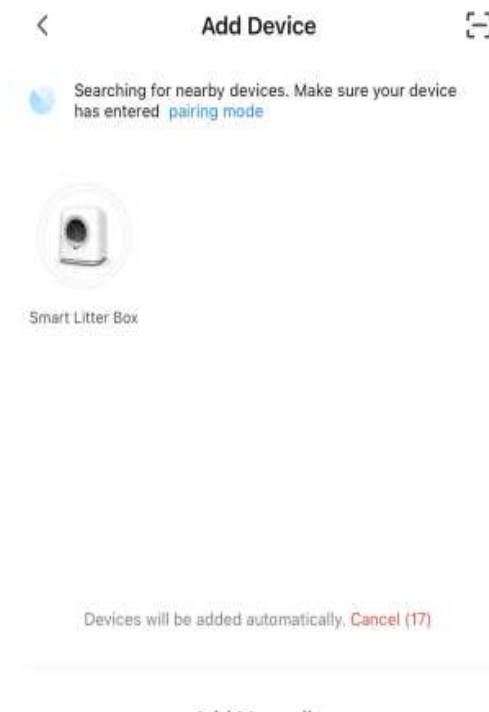

4. Once the device is added, enter your WiFi account and password.

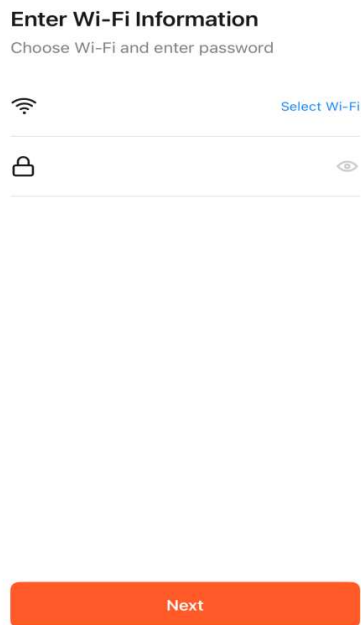

5. After network pairing is completed, the APP will return to the main page, and you can start operating the device.

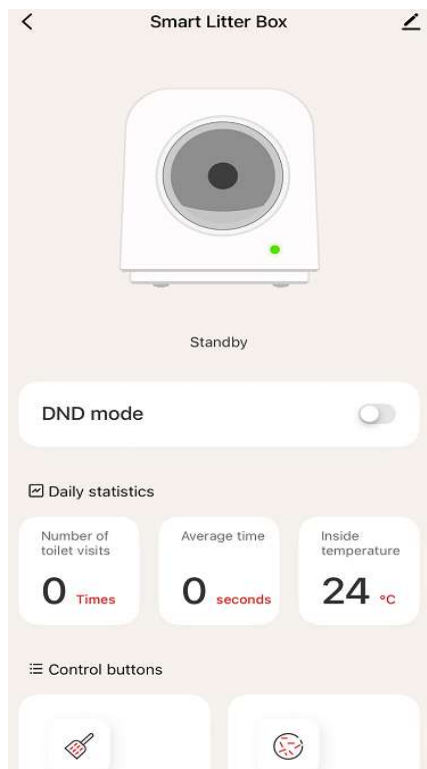

Cleaning Instructions :

Before cleaning the roller, first use the sand dumping function (double-press the button or operate via the APP) to clean all cat litter into the waste bin. Ensure the waste bin is not full before dumping. Then unplug the adaptor to make sure the machine is powered off.

The method for disassembling the roller is shown in the diagram: first remove the upper cover, then the roller can be taken out. Wipe it clean with a wet towel, and ensure the roller is dry before reinstalling it on the base.

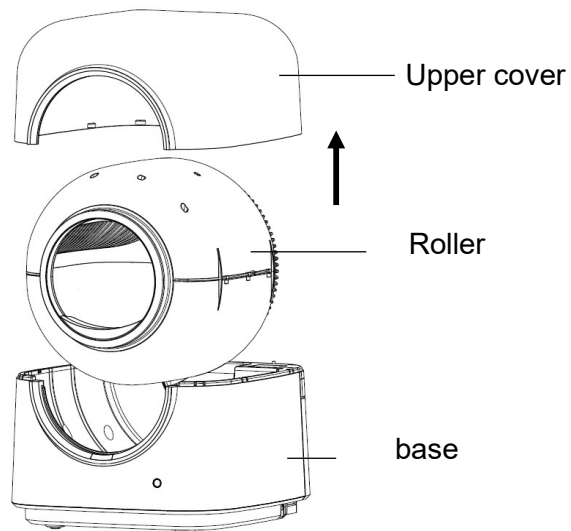

Note: There is no need to align the roller when placing it back on the base. The machine will automatically roll and return to its original position after placement.

Sterilisation Instructions:

Sterilisation mode can only be activated via the APP, with two options: "Manual Sterilisation" and "Intelligent Sterilisation".

Manual Sterilisation: Click the "Sterilisation" button in the APP, and the machine will sterilise the waste bin for 10 minutes, then automatically turn off after completion.

Intelligent Sterilisation: Enable this function in APP Settings - Intelligent Sterilisation. Once enabled, the machine will sterilise the waste bin every 6 hours, lasting 10 minutes each time, and automatically turn off after completion.

Note: The UV sterilisation module is located above the waste bin. Do not open the upper cover or waste bin during sterilisation, otherwise the process will terminate.

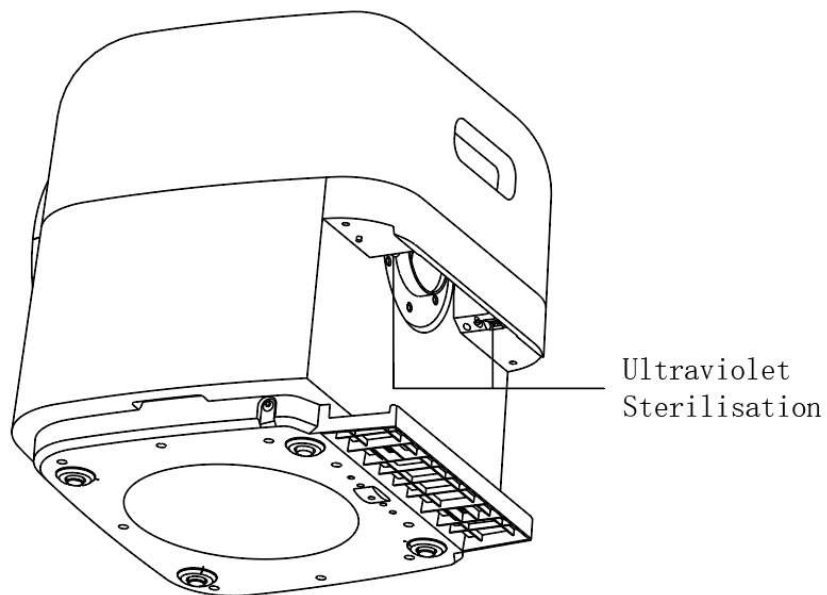

Indicator Status Description /Troubleshooting

Indicator Light Status	Working Status
Green light always on	Machine standby / cleaning / sand dumping
Green light flashing (APP Version)	Machine prompts for network status.
Red light always on	1.The upper cover and collection bin are not installed in place or the cleaning process is interrupted; 2.Urine collection tank full alarm.
Red light flashing	The motor stops running due to resistance.
Blue light always on	Machine detects cat entering or adding litter.
Purple light always on (APP Version)	UV sterilization in progress. (sterilization lasting for ten minutes each time)

Fault Description	Treatment measures
Red light always on	<ol style="list-style-type: none"> 1. Check if the upper cover or toilet compartment is installed in place; 2. Check if there are cats approaching the machine during cleaning or sand dumping Alternatively, enter the machine, and if there is one, the cat will complete the remaining programs after leaving and the green light will remain on. 3. Check if the capacity of the collection bin is full. If it is full, please clean it.
Red light flashing	<ol style="list-style-type: none"> 1. Check whether there are foreign objects stuck in the gear; 2. After confirming that there are no foreign objects stuck, power off and restart.
Machine can' t connect WiFi	<ol style="list-style-type: none"> 1. Check if the WiFi password is correct; 2. Check if the WiFi frequency is 2.4GHz, and if the WiFi frequency is 5GHz,Please replace the router and try again.
Cat litter pads are prone to sticking	Check if the cat litter is sufficient and add it to the MAX marking position.

12 Month Warranty

Thank you for your purchase.

Your new product is warranted to be free from defects in materials and workmanship for the period stated above, from the date of purchase, provided that the product is used in accordance with accompanying recommendations or instructions where provided. This warranty is in addition to your rights under the Australian Consumer Law.

For New Zealand customers, this warranty is in addition to statutory rights observed under New Zealand legislation.

We will provide you with your choice of a refund, repair (where possible) or exchange (availability dependent) for this product if it becomes defective within the warranty period. The business will bear the reasonable expense of claiming the warranty.

This warranty will no longer apply where the defect is a result of alteration, accident, misuse, abuse or neglect.

Please retain your receipt as proof of purchase and contact our Customer Service Centre as listed below, for the entity you purchased this product from, for any difficulties with your product. Warranty claims and claims for expense incurred in returning this product can be addressed to the respective Customer Service Centre.

Our goods come with guarantees that cannot be excluded under the Australian Consumer Law. You are entitled to a replacement or refund for a major failure and compensation for any other reasonably foreseeable loss or damage. You are also entitled to have the goods repaired or replaced if the goods fail to be of acceptable quality and the failure does not amount to a major failure.



If you have any cybersecurity-related concerns or queries, please contact us online via our 'Contact Us' page at <https://www.kmart.com.au/contact-us/> or reach us by phone using the numbers listed below

MADE IN CHINA

CUSTOMER SERVICE:

KMART AU: 1800 124 125

KMART NZ: 0800 945 995

TARGET AU: 1300 753 567

Contact for Kmart Purchases	Contact for Target Purchases
Kmart Australia Ltd. C/-Customer Service Centre 690 Springvale Road, Mulgrave Vic 3170 Customer Service:1800 124 125 (Australia) or 0800 945 995 (New Zealand) or via Customer Help at kmart.com.au	Target Australia Pty Ltd C/-Customer Service 2 Kendall Street, Williams Landing, Vic,3027 Customer Service:1300 753 567 or via Customer Help at target.com.au/help/contact-us



Statement of Compliance

Security standard for consumer grade relevant connectable products
 AUSTRALIA

This statement of compliance has been prepared by, or on behalf of Kmart Australia Limited, who is the manufacturer of the below product. The statement of compliance is made in accordance with the Cyber Security (Security Standards for Smart Devices) Rules 2025, authorized by the Cyber Security Act 2024.

Product manufacturer details	
Name of the manufacturer	Kmart Australia Limited
Address of the manufacturer	1 Middle Rd, Chadstone VIC 3148
Name of the authorized representative	Nick Zhang (Product Technologist)
Address of the authorized representative	801-805, 8th Floor, Zhi Xing International Commerce Building, Railway Garden Crossing, Changping Road, Changping Town, Dongguan, China
Name(s) of other authorized representatives in Australia (if applicable)	N/A
Address(es) of other authorized representatives in Australia (if applicable)	N/A
Product details	
Product type	Automated Cat Litter Box
Batch identifier	43690978
Defined support period for the product	This device will receive all available security updates until 12 February 2026

Declaration

It is declared that, in the opinion of the manufacturer:

1. The product listed in the table above has been manufactured in compliance with the requirements of Part 1 of Schedule 1 of the Cyber Security (Security Standards for Smart Devices) Rules 2025.
2. The manufacturer has complied with any other obligations relating to the product in Part 1 of Schedule 1 of the Cyber Security (Security Standards for Smart Devices) Rules 2025.

It is declared that this statement of compliance has been prepared by, or on behalf of, the manufacturer of the product listed in the table above and is accurate at the date of issue of 7 January 2025.

Prepared by or on behalf of Kmart Australia Limited

Nick Zhang

(Name, function and signature of the signatory of the manufacturer)

Feb. 27, 2026

(Place and date of issue of the statement of compliance)