

Kids Basketball Set

1

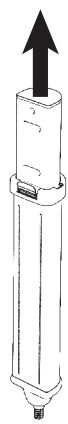

1. Pull out the pole of basketball stand to adjust the height.

2

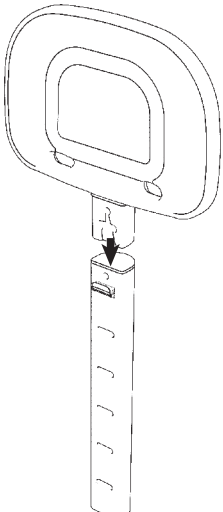

2. Plug the backboard into the pole of the basketball stand.

3

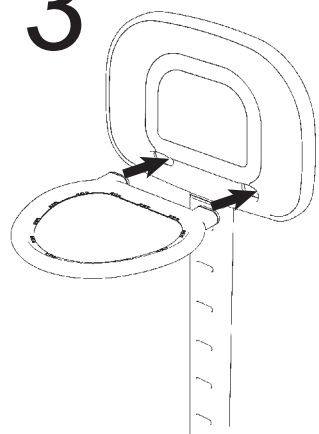

3. Install the hoop to the backboard.

4

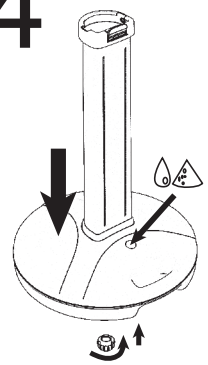

4. Insert the pole of basketball into the pedestal and then tightly screw the nut.

Note: Trickle water or sand into the base container to make the basketball stand stable.

5

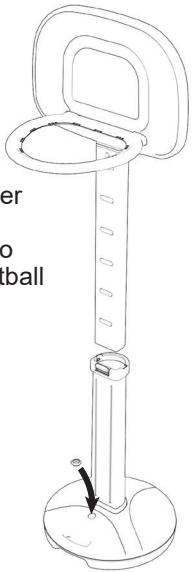

5. After assembling all parts of the basketball stand, make sure the plug is secured into the base.

6

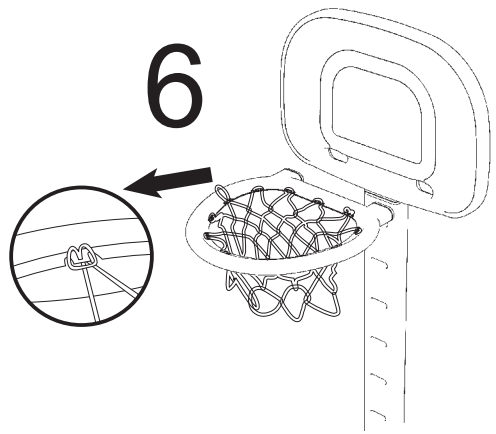

6. Put the basketball net on the hoop.

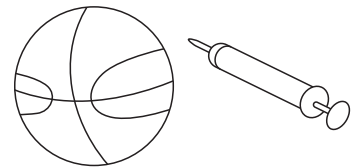

Basketball and pump are included

WARNING: CHOKING HAZARD
SMALL PARTS. NOT FOR CHILDREN UNDER 3 YEARS.

WARNING: FOR SAFETY REASONS, REMOVE ALL TAGS, LABELS AND PLASTIC FASTENERS BEFORE GIVING THIS TOY TO YOUR CHILD.

CAUTION: DO NOT LET PRODUCT OVER INFLATE. USE HAND PUMP ONLY.

WARNING: OUTDOOR USE ONLY. ADULT SUPERVISION RECOMMENDED AT ALL TIME.

WARNING: THE PRODUCT MUST BE ASSEMBLED BY AN ADULT. CHILDREN MUST NOT USE THE PRODUCT UNTIL PROPERLY INSTALLED.



WARNING! SWINGING ON THE RING MAY CAUSE INJURY

PRODUCT MAY VARY SLIGHTLY FROM IMAGE SHOWN. PLEASE KEEP THE PACKAGING FOR FUTURE REFERENCE.