

Assembly Instruction

43637751 MILLIE 1D BEDSIDE TABLE

CARE INSTRUCTIONS:

WIPE CLEAN WITH A SOFT DAMP CLOTH. DO NOT USE ABRASIVE MATERIALS AND SOLVENTS. CHECK AND TIGHTEN ALL PARTS REGULARLY. DO NOT PLACE HOT ITEMS SUCH AS COFFEE CUPS DIRECTLY ON THE SURFACE. KEEP AWAY FROM WATER AND DIRECT SUNLIGHT. STORE IN A DRY PLACE. FOR DOMESTIC USE ONLY. FOR INDOOR USE ONLY. A MILD ODOUR MAY BE PRESENT WHEN FIRST OPENING THIS CARTON. SIMPLY ALLOW TO AIR OUTSIDE AND THIS WILL FADE.

WARNING:

DO NOT STAND OR SIT ON THIS UNIT. DO NOT USE THIS UNIT UNLESS ALL BOLTS AND SCREWS ARE FIRMLY SECURED. DO NOT KNOCK OR DRAG THIS UNIT. USE ONLY ON A FLAT SURFACE. LOAD TOP AND DRAWER EVENLY TO PREVENT FROM TIPPING OVER. THIS PACKAGE CONTAINS SMALL PARTS AND SHARP POINTS. KEEP AWAY FROM CHILDREN AND BABIES. ADULT ASSEMBLY REQUIRED. FAILURE TO FOLLOW THESE WARNINGS COULD RESULT IN SERIOUS INJURY.

MAXIMUM SAFE LOAD: 10KGS FOR TOP, 3KGS FOR DRAWER, 3KGS FOR SHELF.

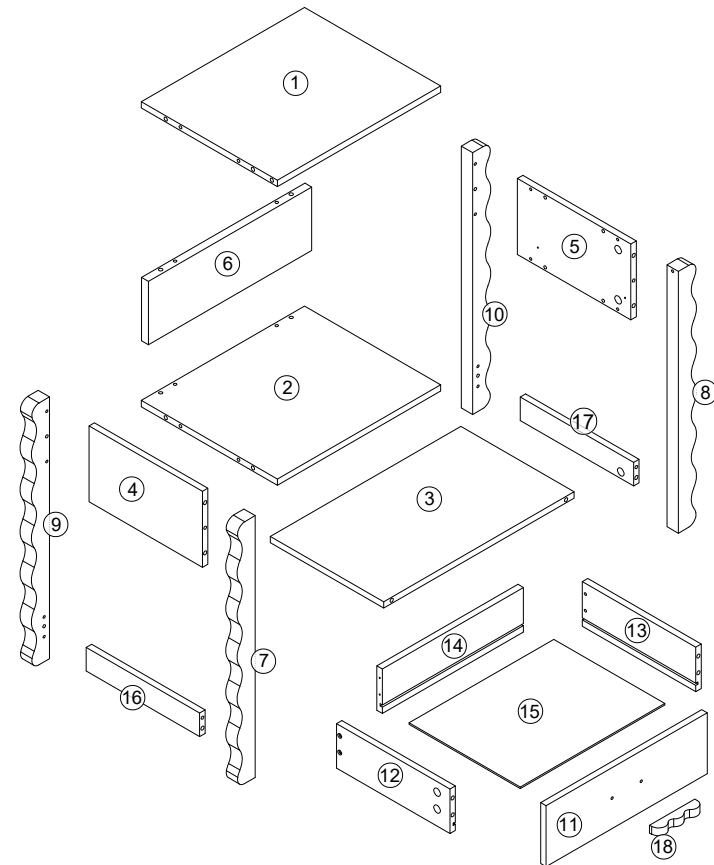
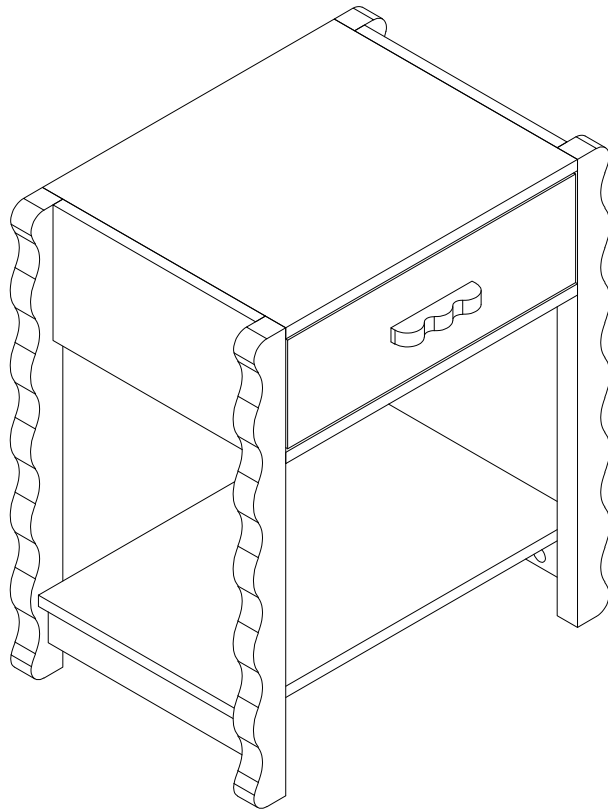



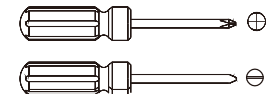











Tools Required (Not Provided)

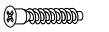





Do not tighten the screws fully during assembly.
Fully tighten screws after the final assembly steps.

Hardware List

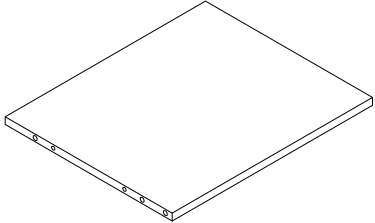
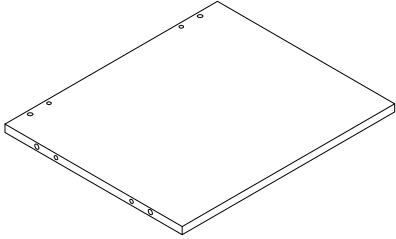
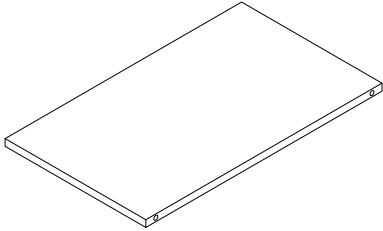
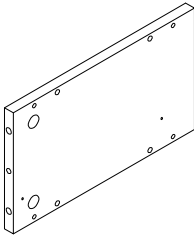
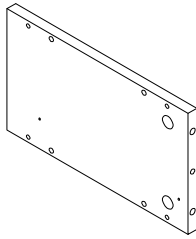
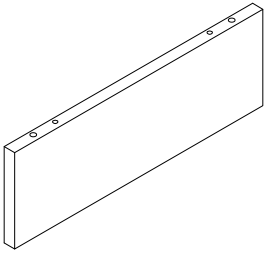
	A	6x35mm	24pcs		E	3x12mm	8pcs		I		1pc	 CR  DR		1pc
	B	15x10mm	24pcs		F	5x50mm	8pcs		J		1pc			
	C	6x30mm	20pcs		G	5x40mm	2pcs		K		4pcs			
	D	4x35mm	4pcs		H	4x25mm	2pcs		CL		DL			1pc

Part List

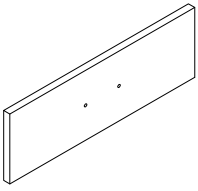
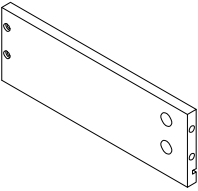
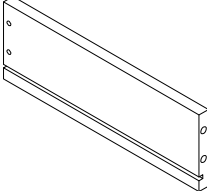
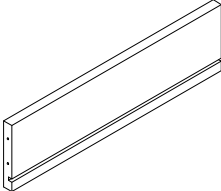
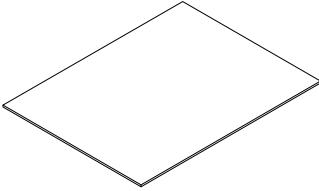
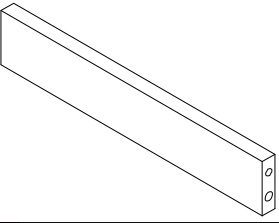
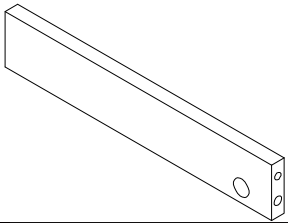
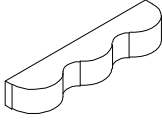
	1	1PC		2	1PC		3	1PC		4	1PC		5	1PC
	6	1PC		7	1PC		8	1PC		9	1PC		10	1PC
	11	1PC		12	1PC		13	1PC		14	1PC		15	1PC
	16	1PC		17	1PC		18	1PC						

Step 1:  Ax10

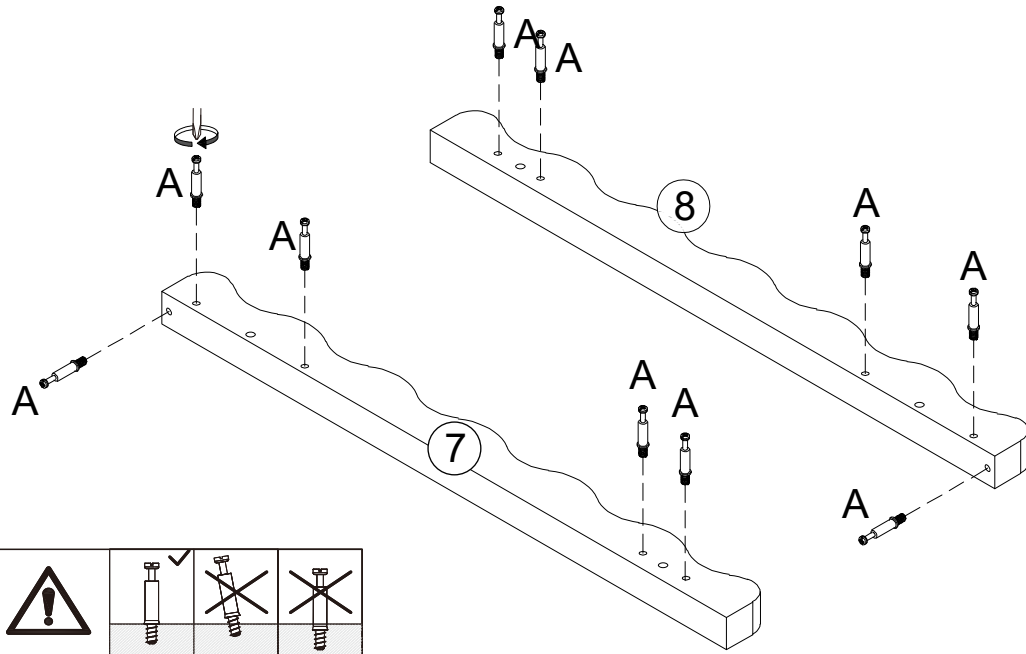

Step 3:  Bx2  Cx1

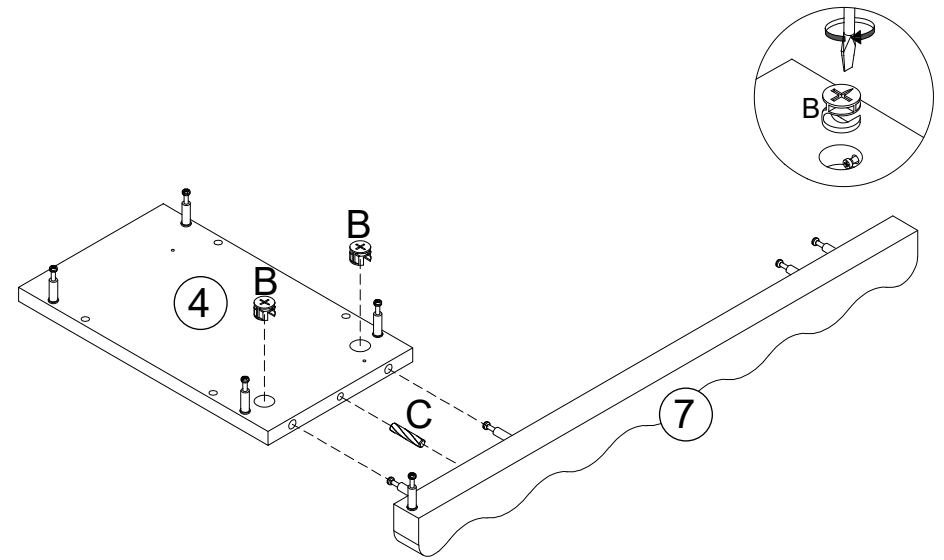

Step 2:  Ax8

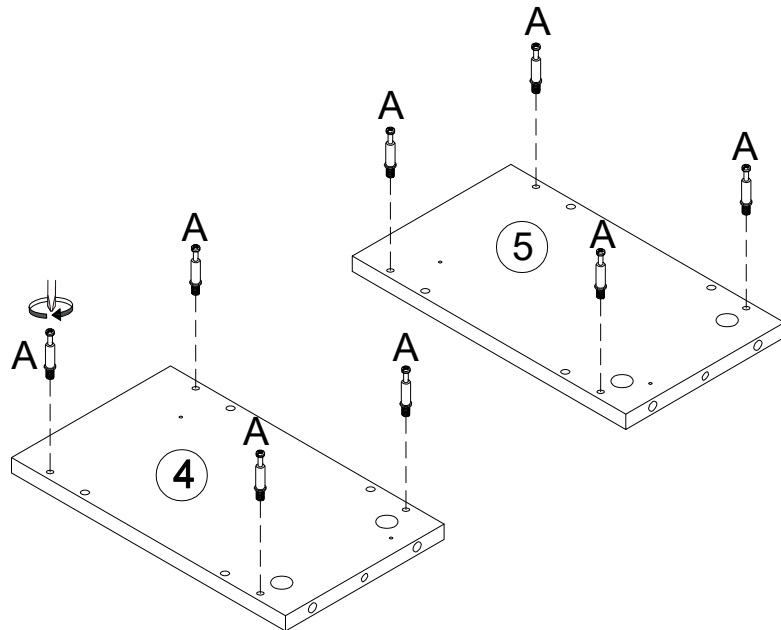

Step 4:  Bx2  Cx1

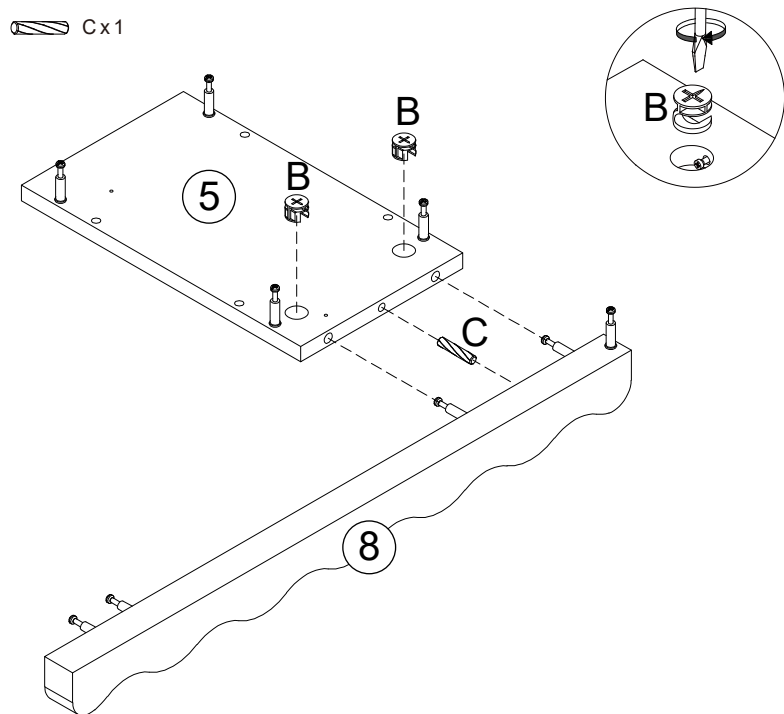

Step 5: Ex2 CLx1

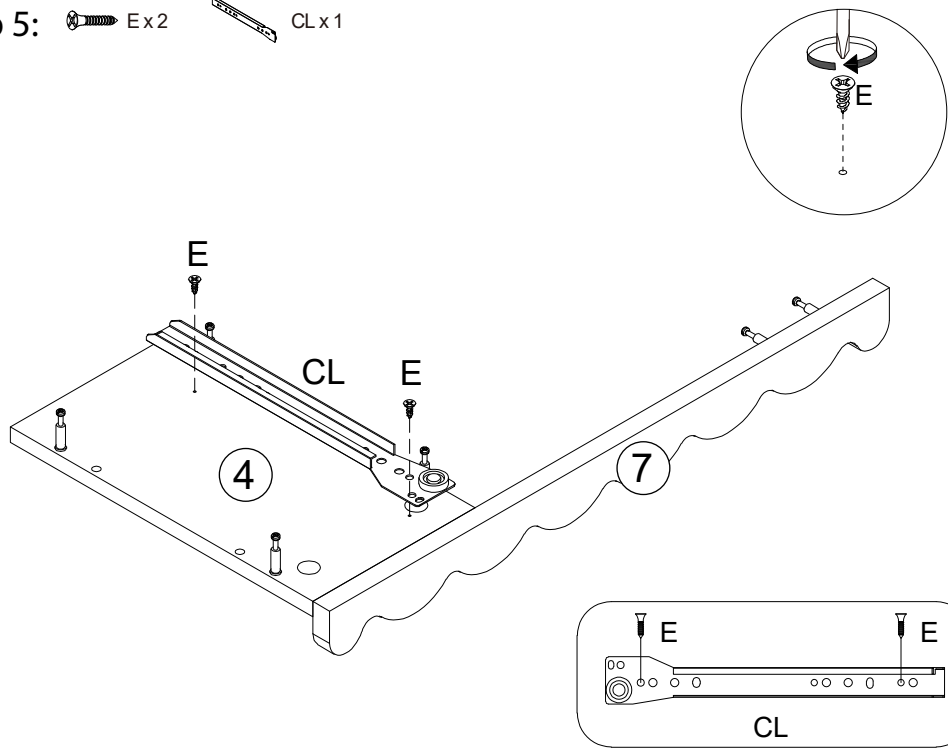

Step 7: Ax2

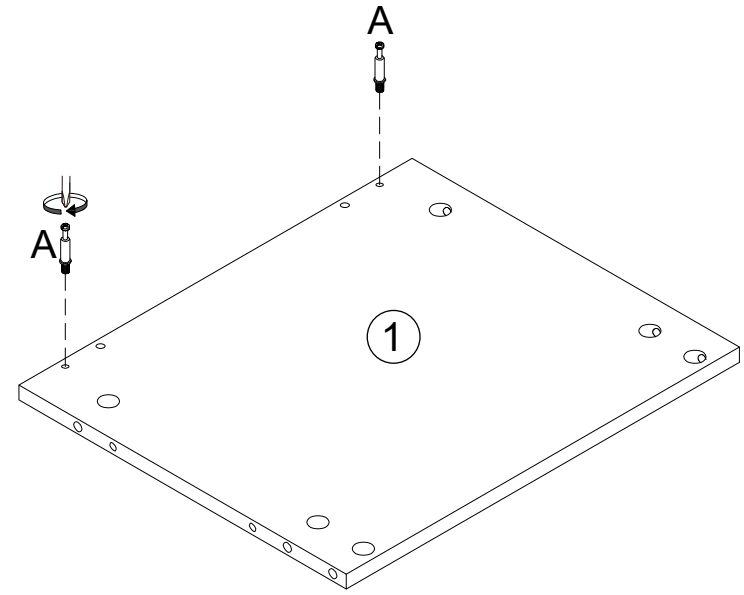

Step 6: Ex2 CRx1

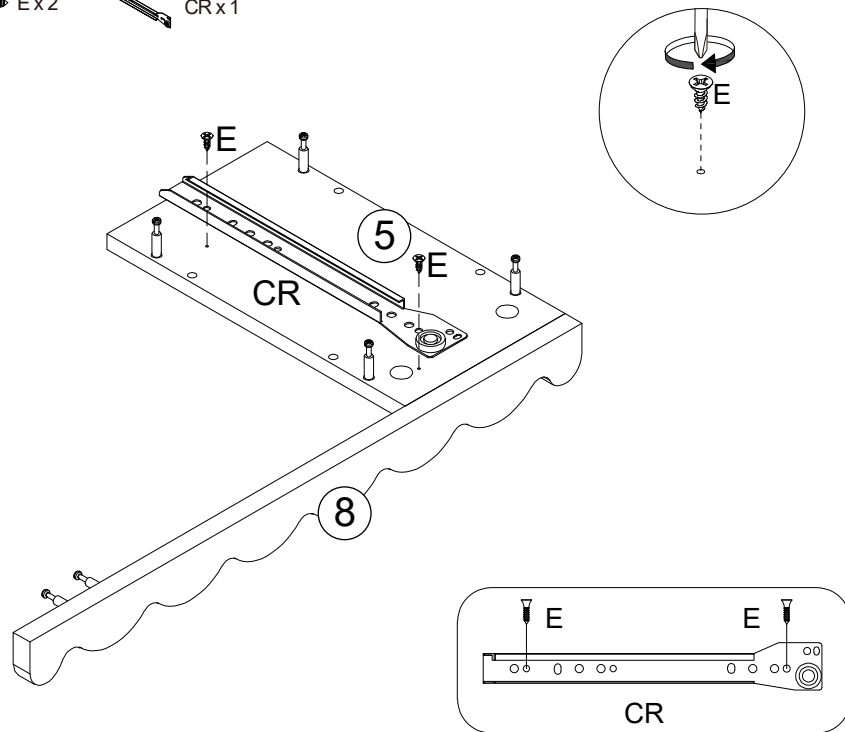

Step 8: Bx2 Cx4 Gx2

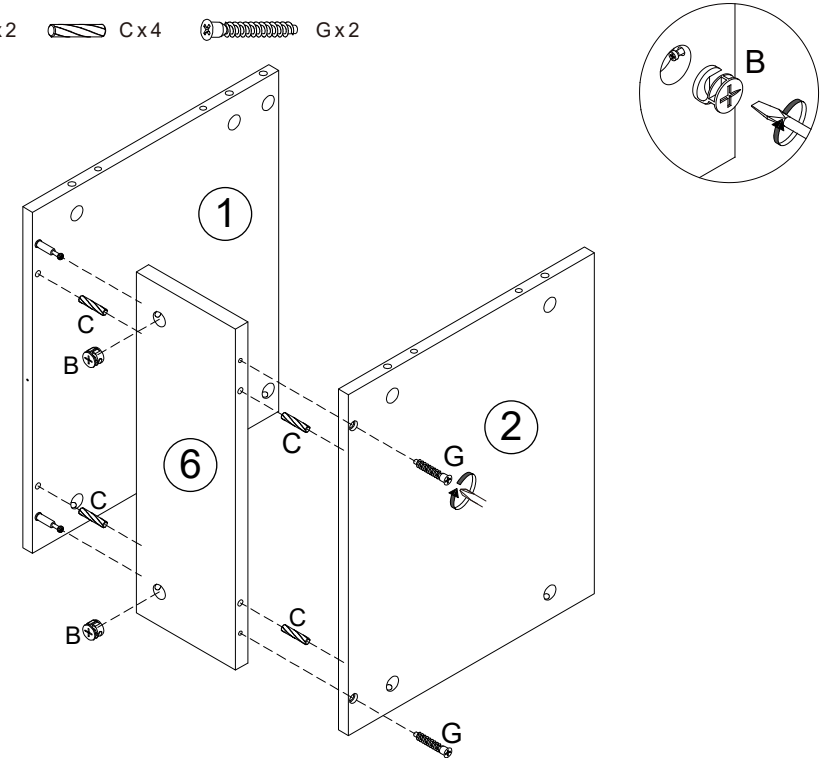

Step 9:  Bx10  Cx8  Ix1

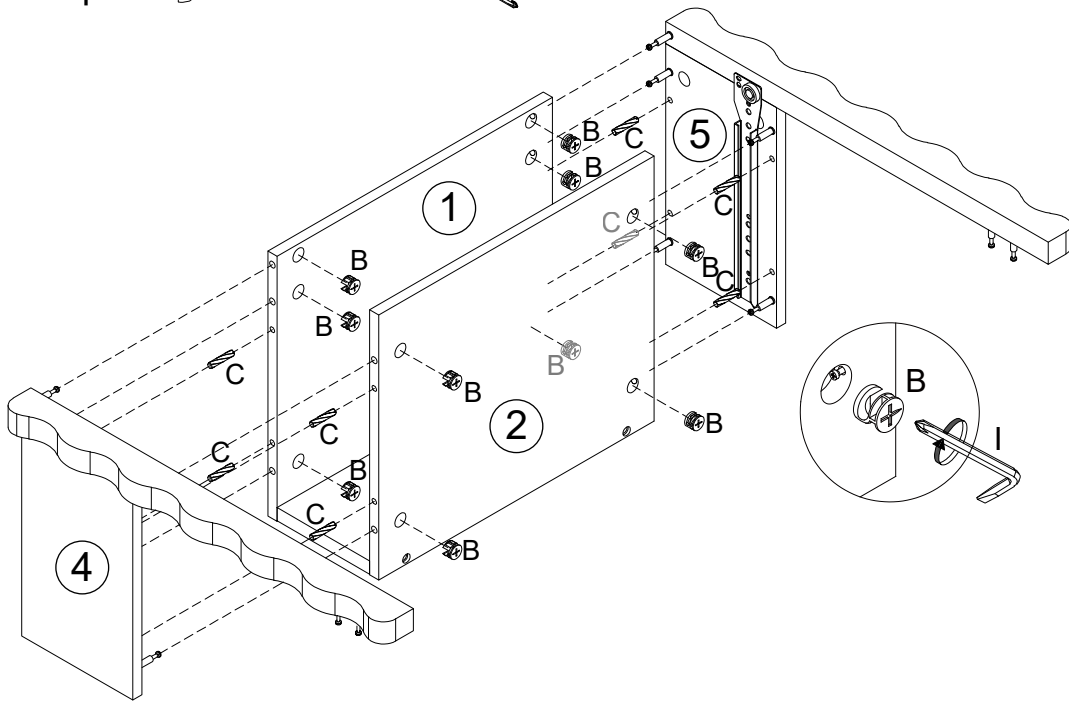

Step 11:  Bx2  Cx2

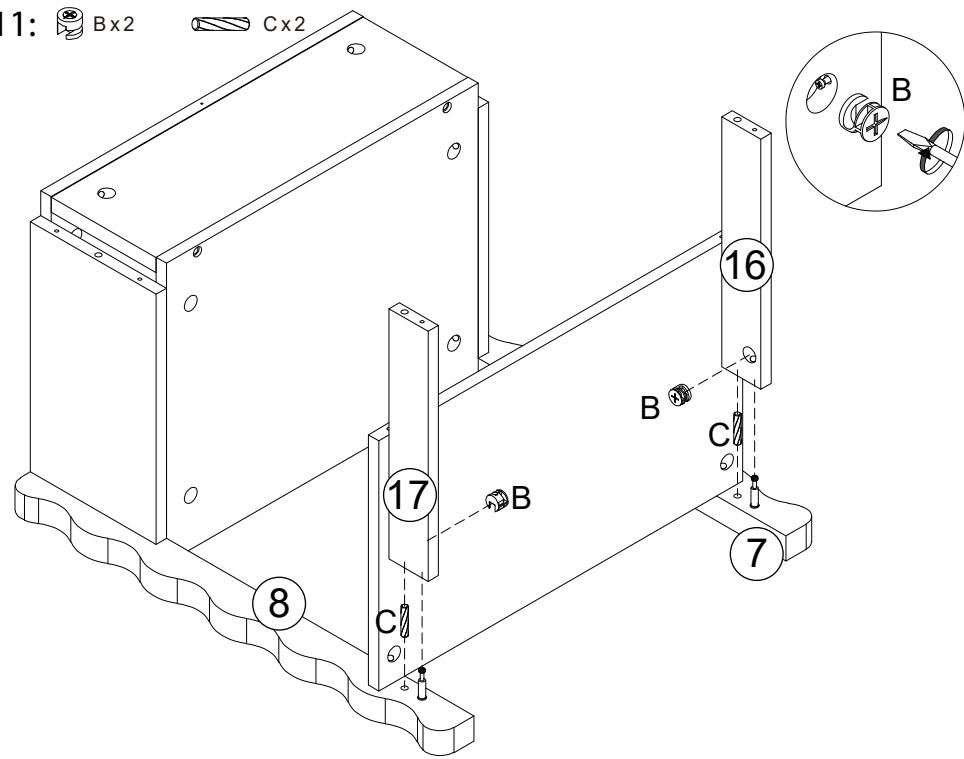

Step 10:  Bx2

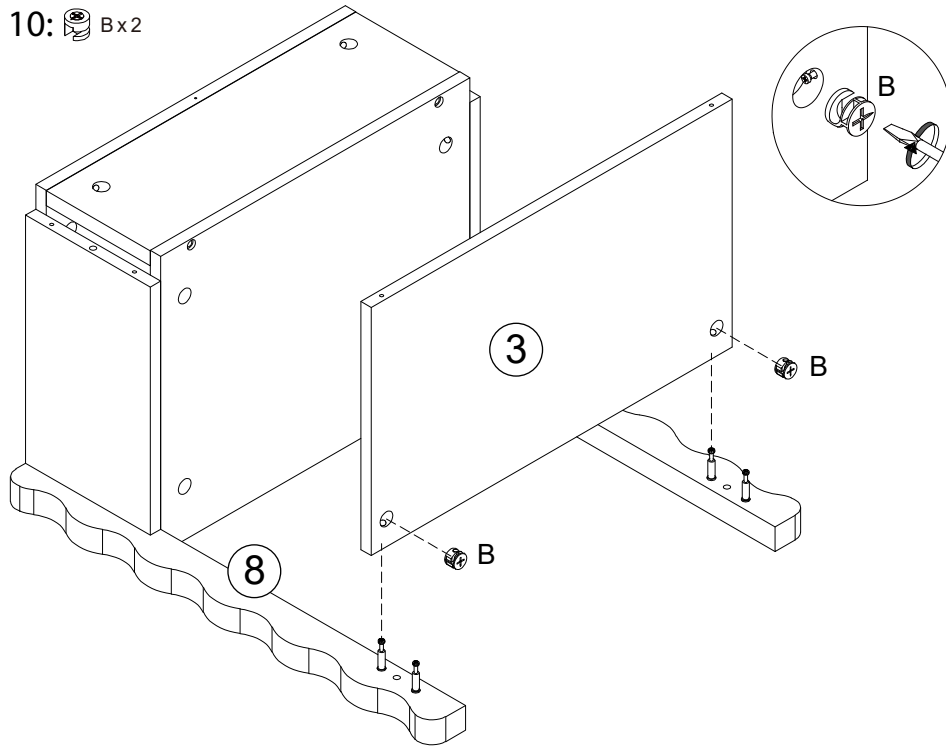

Step 12:  Cx4  Fx8  Kx4

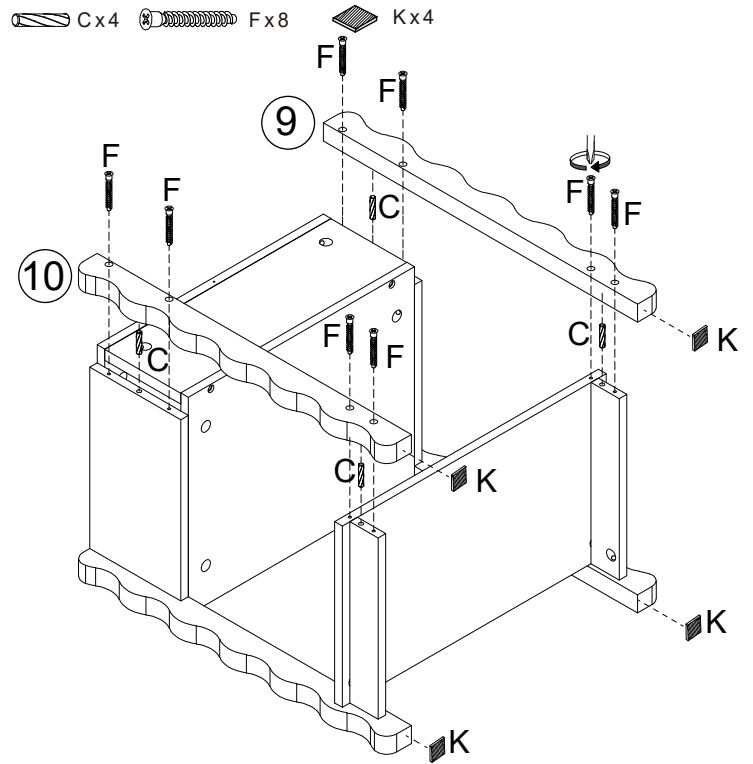

Step 13:  Ax4

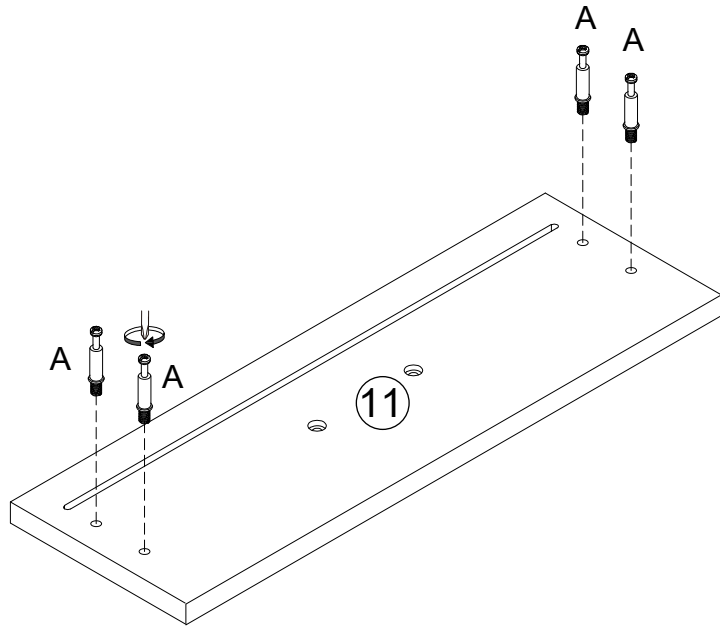

Step 15:

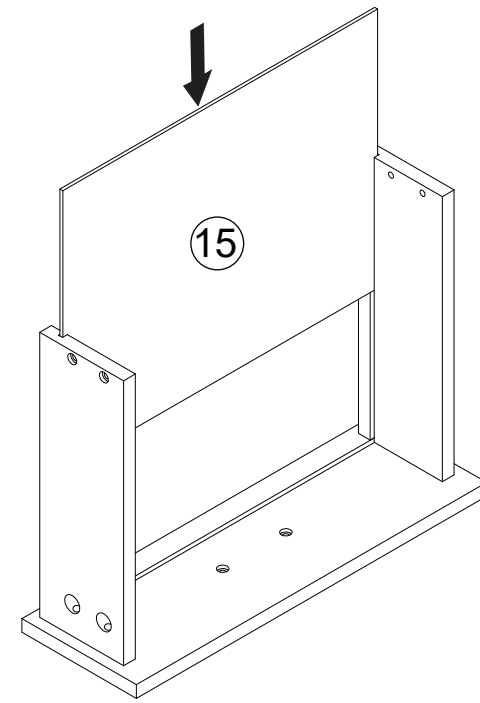

Step 14:  Bx4

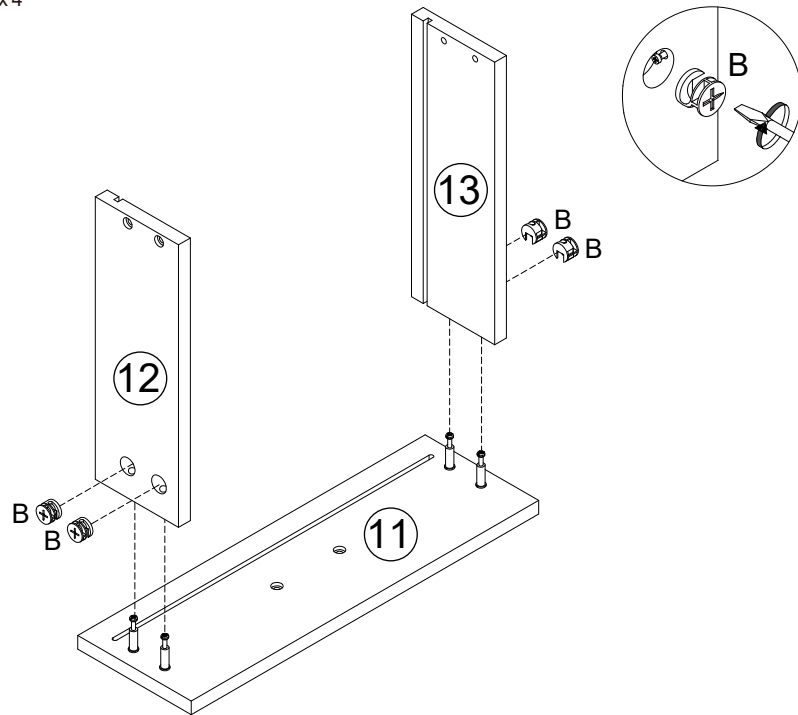

Step 16:  Dx4

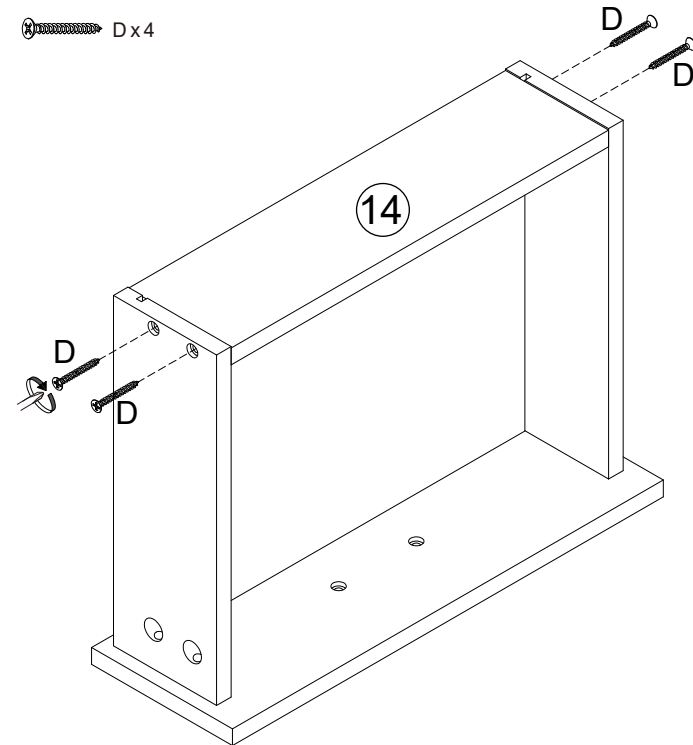

Step 17: Ex4 DLx1 DRx1

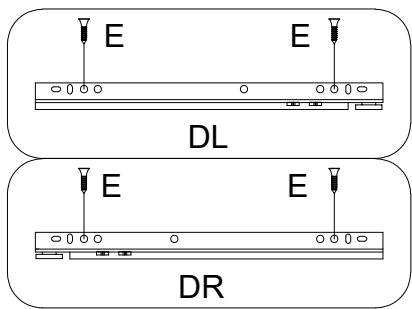
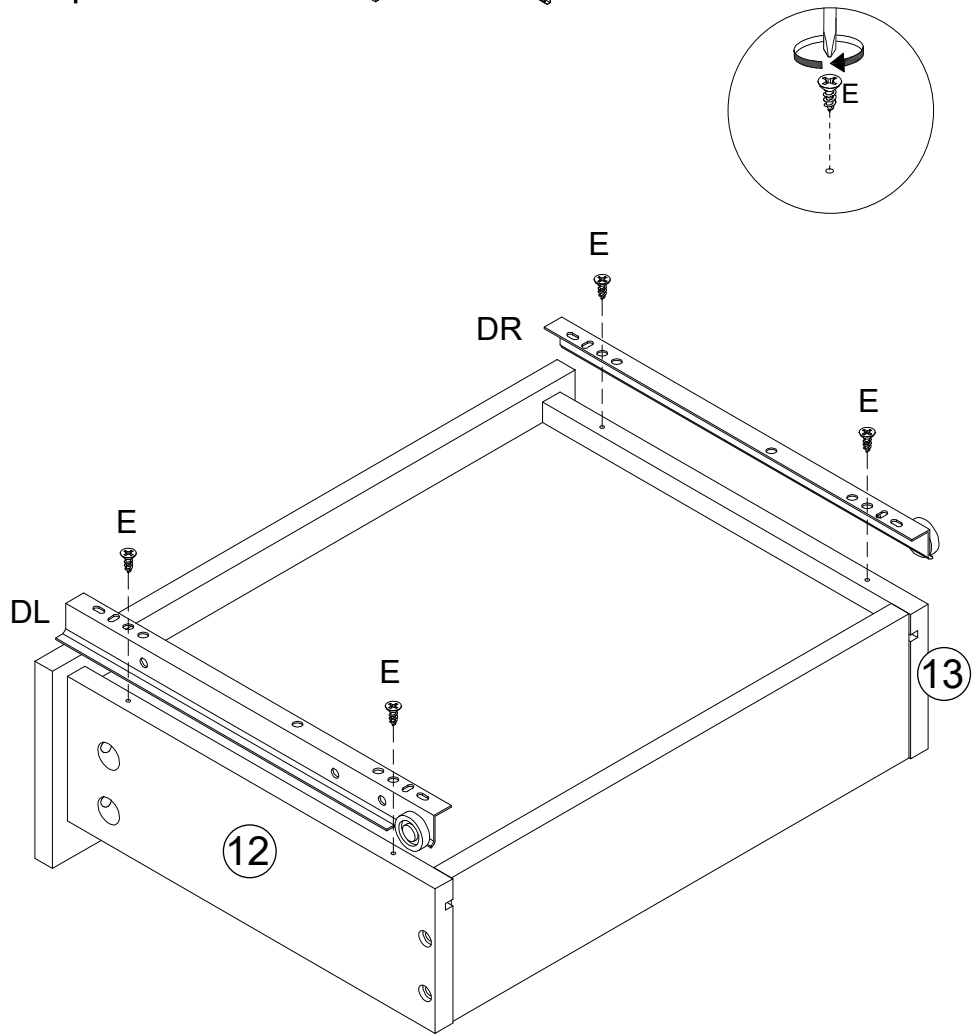

Step 18: Hx2

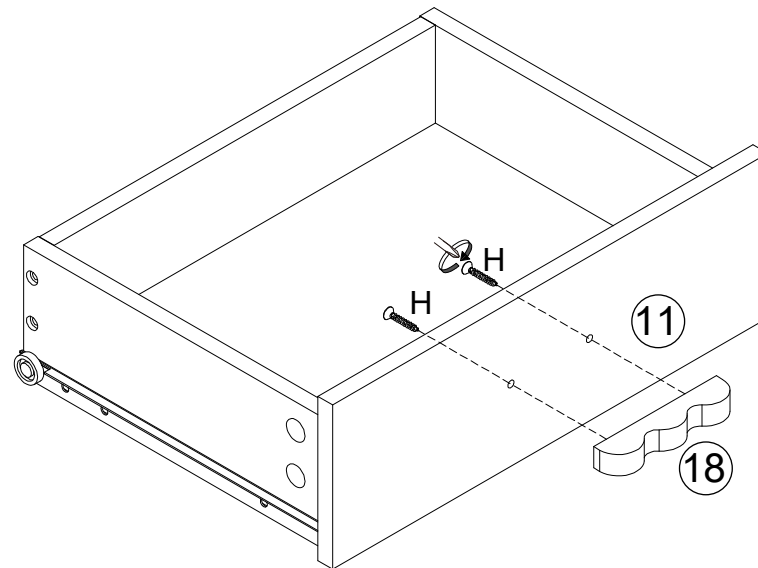

Step 19:

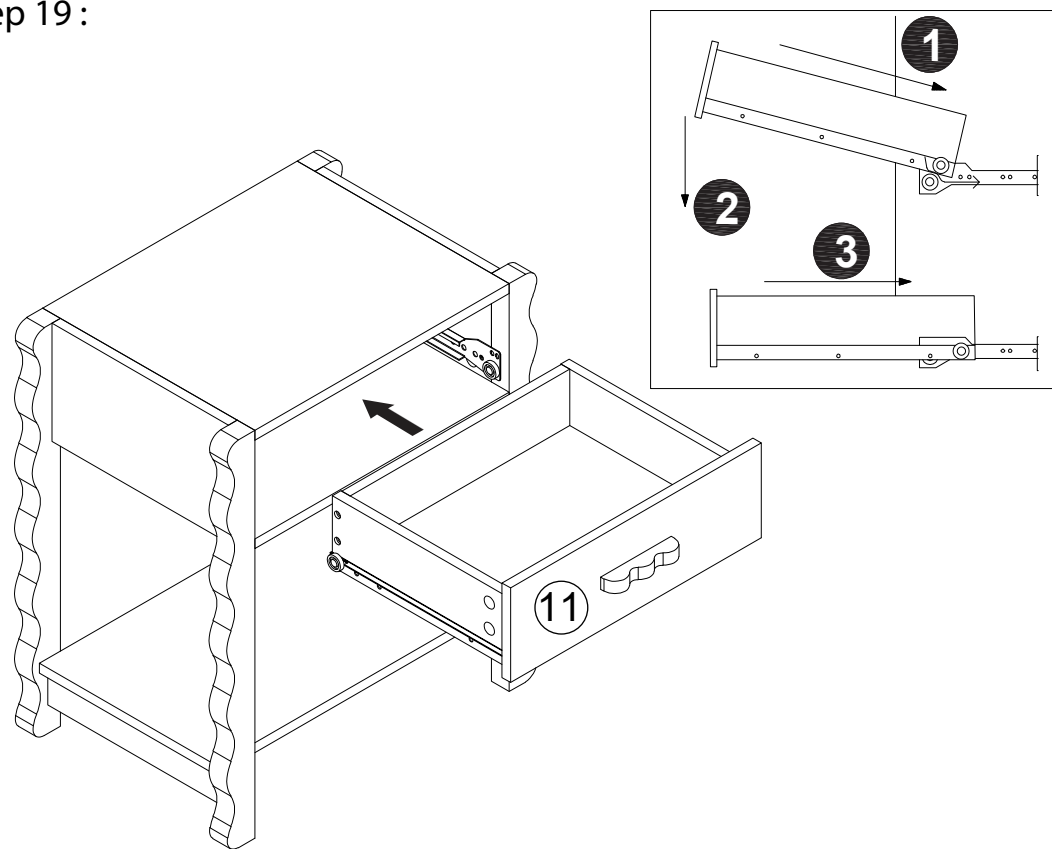

Step 20:  J x 1

Wall

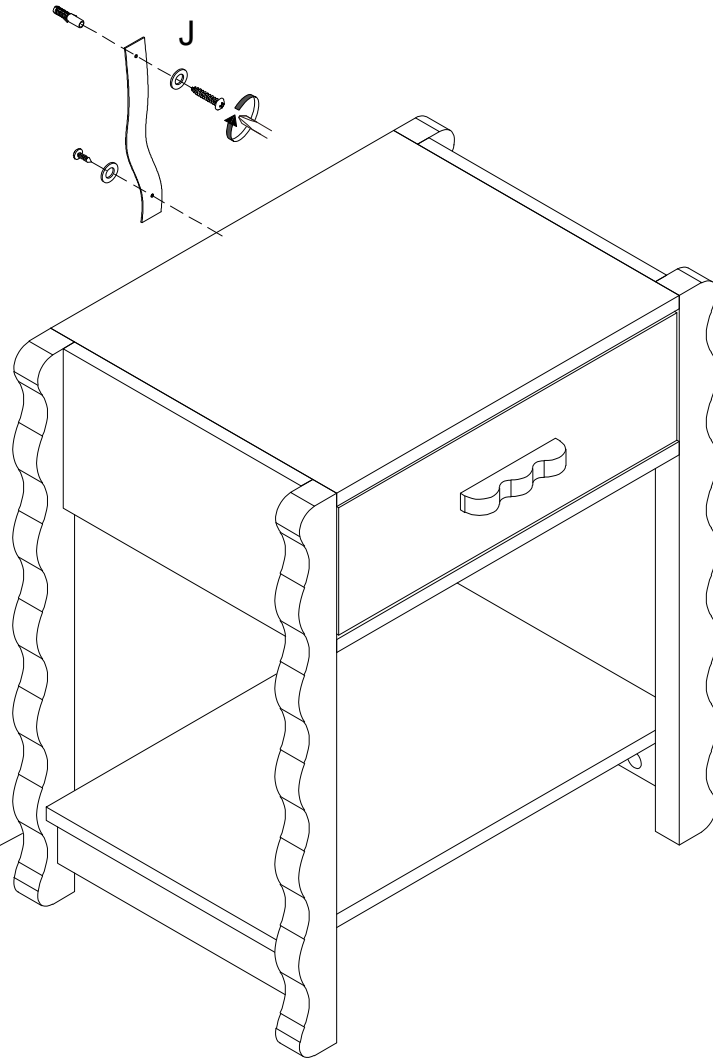

TOPPLING FURNITURE WARNING:

- **ALWAYS secure it with an anchor device.**
- **Please seek professional advice if you are in doubt of what fixing device to use.**
- **Regularly check that anchors are securely maintained.**
- **Use safety drawer locks to prevent children climbing.**
- **Stability of tall items may be affected by thick pile carpet or uneven floors .**
- **Do not place unanchored televisions on furniture .**

CAUTION: for your safety when attaching the anchor fixings, please note the following:

- **Check any electrical wires or plumbing inside the wall before drilling any holes (if you are unsure please seek professional advice from a qualified tradesperson).**

 TOPPLING HAZARD	WARNING: PLEASE SECURE YOUR FURNITURE WITH THE SUPPLIED WALL FIXING. SCAN THE CODE FOR MORE INFORMATION.	
--	--	---

▲ WARNING	
	
Children have died from furniture tipover.	
· ALWAYS secure it with an anchor device.	
· NEVER allow children to stand, climb or hang on drawers, doors, or shelves.	
· NEVER open more than one drawer at a time.	
· Place heavy items down low.	
· Furniture type is at risk of toppling over.	
NEVER put a TV on this furniture 	
This is a permanent label. Do not remove!	