

anko

Cordless Stick Vacuum For Household Use Only



Model No.: EV-6915-S296

Rev 2

Note: The specifications and/or components of this appliance are subject to change without prior notice.

If any accessories should fail during use, please call 1300 105 888 (Australia) or 09 8870 447 (New Zealand) for an immediate replacement. This will save you from returning the product to the store.

If we can assist you in any other way, please feel free to contact us.

1	IMPORTANT SAFETY INFORMATION	3
2	COMPONENTS	5
3	ASSEMBLING THE VACUUM CLEANER	6
3.1	INSTALLING THE EXTENSION TUBE	6
3.2	INSTALLING THE FLOOR HEAD	6
3.3	USING TOOLS WITHOUT THE EXTENSION TUBE	6
3.4	TOOLS AND ACCESSORY HOLDER	7
3.5	BATTERY PACK INSTALLATION	8
3.6	MOUNTING THE CHARGING DOCK	9
3.7	CHARGING	10
4	USING THE VACUUM CLEANER.....	11
4.1	CONTROL PANEL	11
4.2	POWERING ON / OFF	12
4.3	CHANGING SUCTION LEVEL.....	12
4.4	TURBO MODE.....	12
4.5	CLEAN FILTER INDICATOR	13
4.6	CLEAN BRUSH INDICATOR.....	13
4.7	COOLING INDICATOR	13
4.8	BATTERY ICON INDICATOR	13
5	CARE AND MAINTENANCE	14
5.1	EMPTYING THE DUST CANISTER	14
5.2	REMOVING AND CLEANING THE DUST CANISTER AND FILTERS.....	14
5.3	CLEANING THE FLOOR HEAD ROLLER BRUSH	17
6	TROUBLESHOOTING.....	18
7	SPECIFICATIONS	19
8	WARRANTY INFORMATION	20

1 Important Safety Information



Read all instructions thoroughly before use, even if you are familiar with this type of product.

This appliance is not intended for use by persons (including children) with reduced physical, sensory, or mental capabilities, or lack of experience and knowledge unless they have been given supervision or instruction concerning the use of the appliance by a person responsible for their safety.

Children should be supervised to ensure that they do not play with the appliance. Ensure children and babies do not play with plastic bags or packaging materials. Dispose of plastic bags or packaging materials safely.



WARNING - To reduce the risk of fire, electric shock, or injury:

- Do not vacuum water, wet objects, liquids, ashes, hot coals, cigarette butts, matches or any hot, smoking or burning objects, etc.
- Do not pick up flammable or combustible materials (i.e., lighter fluid, petrol, kerosene, etc.) or use in the presence of explosive liquids or vapour.
- Do not pick up toxic material (i.e., chlorine bleach, ammonia, drain cleaner, etc.)
- Do not vacuum toner (for laser printers, copy machines etc.) as there is a risk of fire and explosion.
- Do not vacuum plaster dust, cement dust etc. as the filter will block very quickly.
- Do not immerse in water or any other liquid.
- Do not store or use the vacuum near high-temperature areas.
- Do not use the vacuum cleaner if it is blocked. Turn off and clear all blockages before continuing.
- Do not use the vacuum cleaner with a blocked filter. Clean filter before continuing. (refer to **Care and Maintenance** section).
- Stop using the vacuum immediately if it emits smoke or has a burning smell.
- For electrical safety, repairs must be carried out by a qualified electrician. If the product is damaged, stop using it and dispose of it safely.
- Do not use the vacuum to pick up large objects, hard or sharp objects such as glass, nails, screws, coins, etc. that are likely to cause damage.
- Do not use the product if it has been dropped into water or is damaged.
- Do not handle any part of the charger or vacuum with wet hands.
- Do not use with a damaged cable or charger.
- Do not put any objects into openings.
- Do not use with any opening blocked and do not restrict airflow.
- Do not use without the filter in place.
- Do not attempt to modify this product in any way.
- Empty the dust canister and clean the filters regularly for optimal operation of the vacuum.
- Keep hair, loose clothing, fingers, feet, and body parts away from openings or moving parts.
- For indoor household use only.

- Use only on dry indoor surfaces.
- Keep away from heated surfaces and store indoors in a cool, dry area.
- Use only as described in this manual. Use only the manufacturer's recommended attachments.
- Keep all openings free of dust, lint, hair, and anything that may reduce airflow.
- Use extra care when vacuuming on stairs.
- Operate the charging dock from a power source of the same voltage, frequency and rating as indicated on the product identification plate.
- Only use the charging dock which was supplied with this appliance.
- Unplug charging dock when not in use for extended periods.
- Only use the battery pack specifically designed for this vacuum. Use of any other battery packs may create a risk of injury and fire.
- When the battery pack is not in use, keep it away from other metal objects, like paper clips, coins, keys, nails, screws, or other small metal objects that can make a connection from one terminal to another. Shorting the battery terminals together may cause burns or a fire.



Only use the battery charger supplied with this appliance.

Model No.: ZD024M350080AU 100-240V ~50/60Hz Output: 35V, 800mA

Consumers are cautioned against using and/or purchasing counterfeit and/or inferior quality batteries. These batteries have the potential to cause fire, personal injury, and/or damage to property. These batteries are typically found on online-auction websites or from other retailers and are known to pose a potential safety risk.

Never try to recharge non-rechargeable batteries as they may explode, catch on fire or cause personal injury and/or damage to property.

- May explode if disposed on in fire.
- To prevent injury or burns, do not allow metal objects to contact battery terminals.
- Do not use or store in temperatures above 40°C.
- Only charge the battery between an ambient room temperature of 10°C - 40°C.



The battery pack must be removed from the vacuum before disposal. Contact your local waste management authority for more information on Battery Recycling and disposal regulations in your area.



This symbol on the product or its packaging indicates:

Do not dispose of electrical appliances or batteries as unsorted municipal waste, use separate collection facilities. Contact your local council for information regarding the collection systems available. If electrical appliances are disposed of in landfills or dumps, hazardous substances can leak into the groundwater and get into the food chain, damaging your health and well-being. Please contact your local council or regional authority for more information on the collection, reuse, and recycling programmes.

No liability can be accepted for any damage caused by non-compliance with these instructions or any other improper use or mishandling of the appliance.

This product has not been designed for any uses other than those specified in this manual.

ONLY for domestic use. Industrial or commercial use invalidates the warranty.

Read and Save These Instructions

2 Components

Use this diagram to identify each part before you start using or assembling the vacuum.

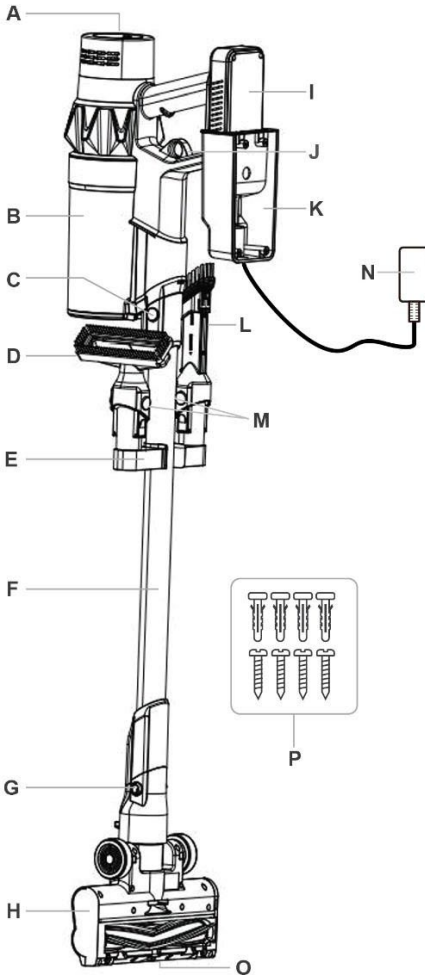

A	Control Panel
B	Dust Canister
C	Tube Release Button
D	Upholstery Brush
E	Accessory Holder
F	Extension Tube
G	Floor Head Release Button
H	Floor Head (with Roller Brush)
I	Battery Pack
J	Dust Canister Release Ring
K	Wall Mountable Charging Dock
L	2-in-1 Crevice Brush
M	Tool Release Button
N	Charging Dock Power Adapter
O	Floor Head LED Indicator (Green)
P	Wall Plugs and Screws

3 Assembling the Vacuum Cleaner

Before fitting or removing parts, ensure the vacuum is powered off.

3.1 Installing the Extension Tube

Insert the extension tube into the main body until it clicks into place. To remove, press the tube release button, then pull the tube straight out.

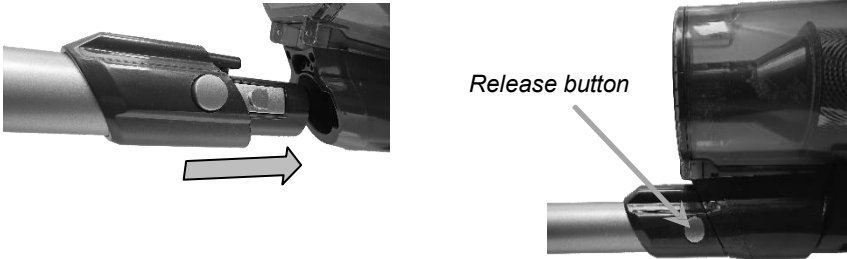

3.2 Installing the Floor Head

Ideal for all types of floor surfaces, such as hardwood, tile, and carpet.

Insert the floor head connector into the other end of the extension tube until it clicks into place. To remove, press the floor head release button, then pull the floor head straight out.



3.3 Using Tools without the Extension Tube

You can use the vacuum as a handheld unit by fitting a tool or the floor head directly to the main body. This is useful for stairs, upholstery, car interiors, and tight corners.

Insert and remove tools in the same way as the extension tube (push in until it clicks, press the release button and pull to remove).



3.4 Tools and Accessory Holder

3.4.1 2-in-1 Crevice Brush

Use for hard-to-reach corners, edges, skirting boards, and around furniture.

- **Brush mode:** Slide the brush down until it clicks into place.
- **Crevice mode:** Press the release button and slide the brush up.

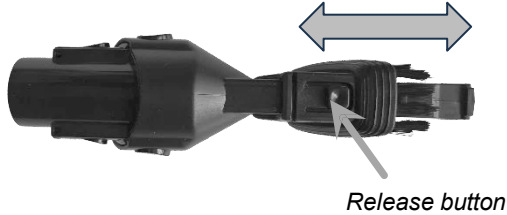

3.4.2 Upholstery Brush

Use for sofas, curtains, and other fabric surfaces.



3.4.3 Accessory Holder

The accessory holder clips onto the extension tube to store the supplied tools. Clip the holder onto the tube with the posts facing upward, then push the tools onto the holder.



3.5 Battery Pack Installation

IMPORTANT: Only use the supplied charger and battery pack.

Slide the battery pack onto the bottom of the handle until it clicks into place. The battery fits in one direction only.

Note: After fitting, gently pull on the battery pack to check it is locked in place.



To remove the battery pack (for separate charging), press the battery release button, then slide the battery pack straight out.

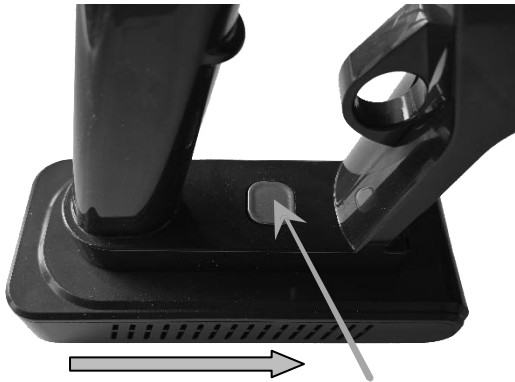

Release button

3.6 Mounting the Charging Dock

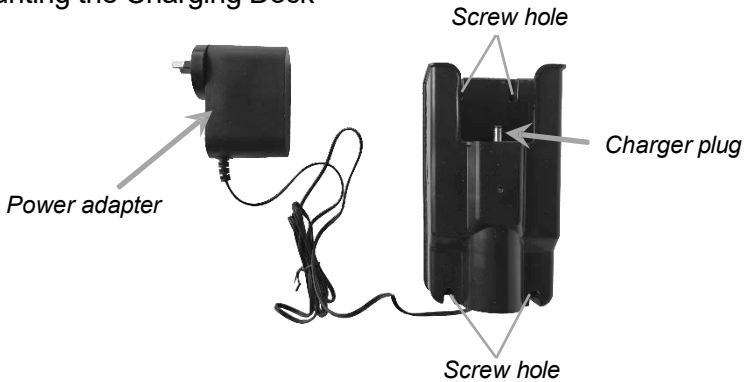

The charging dock can be wall mounted for convenient storage and charging. Before mounting, make sure there is enough clearance for the vacuum to hang freely and be removed easily.

- a) Choose a suitable wall location near a power outlet, out of direct sunlight, and away from heat sources.
- b) Do not mount the charging dock on unstable surfaces.
- c) Check the mounting area for hidden electrical wiring, pipes, or cables before drilling.
Important: If you are unsure about drilling into the wall, seek advice from a qualified person.
- d) Hold the charging dock against the wall at the desired height and use the dock as a template to mark the screw hole positions.
- e) Drill the holes at the marked positions.
- f) Insert the supplied wall plugs into the holes.
- g) Align the charging dock with the holes, then secure it using the supplied screws.
- h) Check the dock is firmly attached, then slide the vacuum onto the dock until it connects with the charger plug.
- i) Plug the power adapter of the charging dock into the wall outlet.

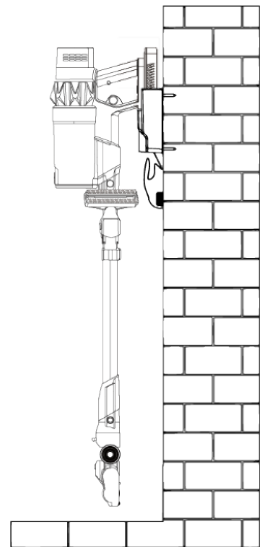

3.7 Charging

Note: Fully charge the vacuum before first use.

You can charge the vacuum while it is stowed on the charging dock.

You can also remove the battery pack and charge it separately; however, the battery percentage and full-charge indication are shown only when the battery is installed in the vacuum.

Before charging, make sure the vacuum is powered off.

- a) Slide the vacuum into the charging dock until it is fully inserted and connected to the charger plug.
- b) Ensure the power adapter of the charging dock is plugged into a wall outlet and switched on.
- c) While charging, the lightning icon flashes on the control panel and the battery percentage display increases until it reaches 100%. A full charge can take up to 4 hours.



- d) When fully charged, the lightning icon stops flashing and remains on. After 30 minutes, the control panel display will automatically turn off.

4 Using the Vacuum Cleaner

4.1 Control Panel

The control panel shows battery level, suction power, and warning indicators so you can monitor the vacuum at a glance.

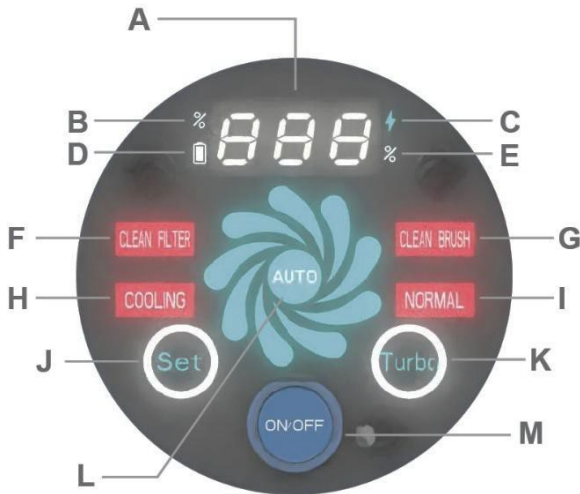

A	Battery Level
B	Battery Percentage Icon (Charging)
C	Charging (Lightning) Icon
D	Battery Icon
E	Battery Percentage Icon
F	Clean Filter Indicator
G	Clean Brush Indicator
H	Cooling Indicator
I	Normal Indicator
J	Set Button
K	Turbo Button
L	Power Level / Auto Indicator
M	ON/OFF Button

4.2 Powering On / Off

Press the **ON/OFF** button on the control panel to turn the vacuum on.

Note: You cannot turn on the vacuum while it is charging.

The vacuum starts in **Low** suction. The power level indicator shows **3 wind icons**, and the **Normal** indicator lights up to confirm the vacuum is running.

Note: If using the floor head accessory, the floor head LED indicator will illuminate green.

To turn the vacuum off, press the **ON/OFF** button again.

4.3 Changing Suction Level

To manually adjust the suction level, press the **Set** button to cycle through the suction levels in order:

- **Medium (6 wind icons)**
- **High (9 wind icons)**
- **Auto (Auto icon)**
- **Low (3 wind icons)**

In **Auto** mode, the vacuum automatically adjusts suction based on the floor surface and the amount of dust, helping balance cleaning performance and battery life.

The **Power level indicator** on the control panel illuminates based on the current suction level.

4.4 Turbo Mode

Press the **Turbo** button to activate maximum suction for stubborn dirt or heavier debris.

- Turbo mode runs for 30 seconds each time it is activated.
- After 30 seconds, Turbo mode exits automatically and the vacuum returns to the previous suction level.
- Turbo mode cannot be activated again for 1 minute after use.
- Turbo mode is not available when the battery level is below 30%.

Note: Turbo mode drains the battery faster.

4.5 Clean Filter Indicator

The vacuum is fitted with a dust sensor that monitors the filter during use. If the filter becomes clogged or needs cleaning, the **CLEAN FILTER** indicator light illuminates.

If the **CLEAN FILTER** indicator illuminates, switch off the vacuum and clean the filter (see **Care and Maintenance**).

4.6 Clean Brush Indicator

The vacuum is fitted with a sensor that detects if the floor head rotary brush becomes jammed.

If the brush becomes jammed, the floor head stops and the **CLEAN BRUSH** indicator light illuminates.

If the **CLEAN BRUSH** indicator illuminates, switch off the vacuum and clear the brush (see **Care and maintenance**).

4.7 Cooling Indicator

The vacuum is fitted with a temperature sensor that monitors the battery temperature during charging. If the battery becomes too hot to charge, charging stops and the battery is allowed to cool. The **COOLING** indicator light illuminates.

When the battery cools to a safe temperature, charging resumes automatically.

4.8 Battery Icon Indicator

When the battery level drops below **20%**, the battery icon flashes. Charge the vacuum as soon as possible.

5 Care and Maintenance

5.1 Emptying the Dust Canister

To maintain best performance, empty the dust canister after each use, or sooner if suction drops or the canister becomes full.

Switch off the vacuum before emptying the dust canister.

Hold the vacuum over a bin, then push down on the latch on the dust canister to open the lid and empty the contents into the bin. Tap the canister gently to help loose dirt fall out. Close the lid securely after emptying.

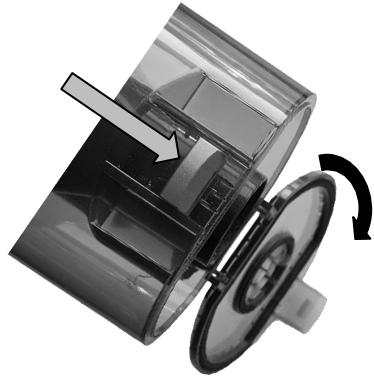

5.2 Removing and Cleaning the Dust Canister and Filters

Removal

- To remove the dust canister from the vacuum, pull the dust canister release ring and slide the dust canister forward to remove it.



- Pull the rubber tab upwards to remove the soft filter from the top of the dust canister.

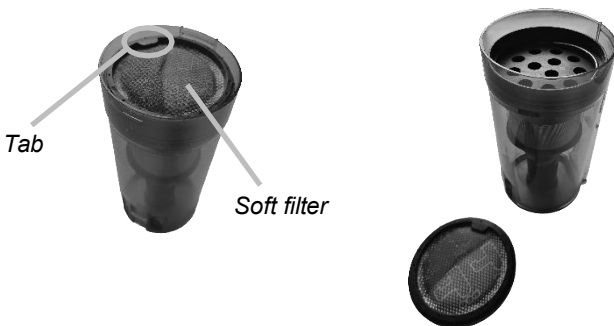

- Lift the metal filter out of the dust canister with the handle.

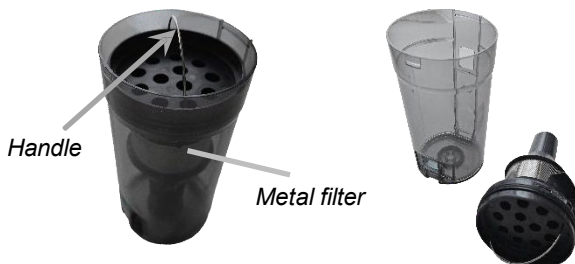

- To remove the exhaust HEPA filter (rear of vacuum, under the control panel), twist the cover clockwise to unlock, then remove the cover. Grip the HEPA filter and pull it straight out.



Cleaning

- Empty any remaining debris from the dust canister, then rinse it with clean water.
- Tap the metal filter gently to remove loose debris. Rinse under cold running water and use a soft brush to clean the mesh and remove any remaining dirt.
- Rinse the soft filter and HEPA filter under cold water only. Do not use detergent or abrasives.
- Shake off excess water and allow all parts to dry completely before refitting.

IMPORTANT: Do not refit the parts until they are completely dry. Do not dry parts using a heater, tumble dryer, dishwasher, or direct sunlight.

Tip: For best performance, clean the filters regularly, for example once a month, depending on how often you use the vacuum.

Refitting

After cleaning, reassemble the parts as follows:

- Insert the metal filter into the dust canister. Make sure the filter notch is aligned with the slot on the dust canister, as shown, before pushing it fully into place.

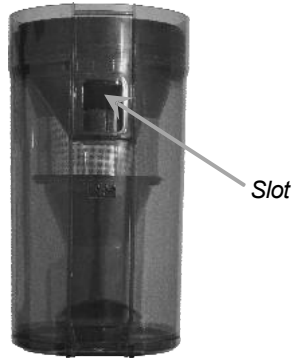

- Fit the soft filter back into place on the top of the dust canister.
- Refit the dust canister onto the vacuum until it clicks into place.
- Insert the HEPA filter into the housing until it is seated snugly around the edge of the control panel. Refit the cover and rotate counterclockwise to secure it in place.



IMPORTANT: Never operate the vacuum without the dust canister and filters fitted.

5.3 Cleaning the Floor Head Roller Brush

The roller brush in the floor head can be removed for easier cleaning of hair and debris. Clean the roller brush every 4-5 cleaning sessions to help prevent blockages or jamming.

Before you begin, remove the floor head from the extension tube or main body.

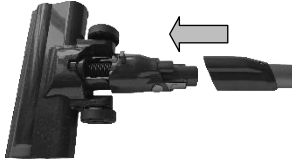

- a) Turn the floor head over.
- b) Push upwards on the thumb recess to unlock the side cover, then slide the roller brush out.



- c) Remove any hair or debris from the roller brush and roller brush housing. If hair is wrapped around the roller brush, use scissors to cut it away, taking care not to damage the bristles.



- d) Insert the roller brush back into the housing (it fits in one direction only). Close the side cover and press down until it clicks into place.

6 Troubleshooting

Problem	Possible Solution
Vacuum will not turn on	<p>Ensure the battery pack is fitted properly.</p> <p>Battery is flat. Recharge the battery.</p> <p>Remove the vacuum from the charging dock before trying to turn it on.</p>
Vacuum stops during use	<p>Battery is very low. Recharge the vacuum.</p>
Vacuum is not charging	<p>Check that the power adapter is plugged in securely at the wall outlet and switched on. Use the supplied power adapter/charger only.</p> <p>Make sure the vacuum is fully inserted into the charging plug on the dock.</p> <p>Check that the battery pack is fitted correctly.</p>
<p>CLEAN BRUSH indicator is ON</p> <p>Roller brush is not spinning</p>	<p>Switch off the vacuum and clean the roller brush. It may be entangled with hair or used in extreme conditions.</p> <p>If the floor head's LED light is not illuminated, there may be a connection issue between the vacuum and the floor head. Refit the floor head and ensure it clicks into place.</p>
Noisy operation	<p>Switch off the vacuum and clear hair/debris from the roller brush and roller brush housing.</p> <p>Empty the dust canister if it is full.</p> <p>Check the extension tube, accessories, and air inlet and clear any blockage.</p>
Suction is not strong	<p>Battery may be low. Fully recharge the battery.</p> <p>Suction may be set to Low. Press the Set button on the control panel to select a higher suction level, or press the Turbo button for maximum suction power (Turbo runs for 30 seconds).</p> <p>Dust canister and filters may be full. Empty the dust canister and clean the filters.</p> <p>Check the extension tube, accessories, and air inlet and clear any blockage.</p>
CLEAN FILTER indicator is ON	<p>Empty the dust canister and clean the filters.</p>
COOLING indicator is ON	<p>Let the vacuum rest until the battery cools down before using it again; the COOLING indicator will turn off once the temperature returns to normal.</p> <p>If the battery is too hot to charge, allow it to cool before charging it; the COOLING indicator will turn off once the temperature returns to normal.</p>

Error Code Displayed on the Control Panel

Code	Possible Solution
E2	Switch off the vacuum. Check the roller brush for foreign objects or moisture and remove/dry as needed. If the code remains, contact Customer Service.
E5	Unplug the power adapter, wait 1 minute, then plug it in again. Ensure you are using the supplied power adapter only. If the code remains, contact Customer Service.
E6	Unplug the power adapter and plug it into a different wall outlet. Use the supplied power adapter only. If the code remains, contact Customer Service.
E7	Empty the dust canister and clean/dry the filters before refitting.
E8	The ambient temperature is outside the operating limit. Move the vacuum to an area within the operating temperature range.
00	Low battery. Recharge the battery.

7 Specifications

Model	EV-6915-S296
Battery	29.6V 2200mAh Li-ion
Charger Model	ZD024M350080AU
Charger Input	100-240V ~50/60Hz
Charger Output	35Vd.c., 800mA
Charging Time	Up to 4 hours
Operating Time	Medium: ~23 min High: ~15 min Auto: ~60 min Turbo: ~30 s Note: Actual operating times may vary based on floor type and tool used.

8 Warranty Information

12 Month Warranty

Thank you for your purchase.

Your new product is warranted to be free from defects in materials and workmanship for the period stated above, from the date of purchase, provided that the product is used in accordance with accompanying recommendations or instructions where provided. This warranty is in addition to your rights under the Australian Consumer Law. For New Zealand customers, this warranty is in addition to statutory rights observed under New Zealand legislation.

We will provide you with your choice of a refund, repair (where possible) or exchange (availability dependent) for this product if it becomes defective within the warranty period. The business will bear the reasonable expense of claiming the warranty. This warranty will no longer apply where the defect is a result of alteration, accident, misuse, abuse, or neglect.

Please retain your receipt as proof of purchase and contact our Customer Service Centre as listed below, for the entity you purchased this product from, for any difficulties with your product. Warranty claims and claims for expenses incurred in returning this product can be addressed to the respective Customer Service Centre.

Our goods come with guarantees that cannot be excluded under the Australian Consumer Law. You are entitled to a replacement or refund for a major failure and compensation for any other reasonably foreseeable loss or damage. You are also entitled to have the goods repaired or replaced if the goods fail to be of acceptable quality and the failure does not amount to a major failure.

Contact for Kmart purchases	Contact for Target purchases
Kmart Australia Ltd. C/- Customer Service Centre L2/ 1 MIDDLE ROAD, CHADSTONE VIC 3148 AUSTRALIA Customer Service: 1800 124 125 (Australia) or 0800 945 995 (New Zealand) or via Customer Help at kmart.com.au	Target Australia Pty Ltd. C/- Customer Service Centre L2/ 1 MIDDLE ROAD, CHADSTONE VIC 3148 AUSTRALIA Customer Service: 1300 753 567 or via Customer Help at target.com.au/help/contact-us

IMPORTANT! For all technical queries or difficulties in operating the product and for spare parts, contact H.E. Group customer service 1300 105 888 (Australia) and 09 8870 447 (New Zealand).