

anko

Air Purifier

Model: PF00-22380

User Manual

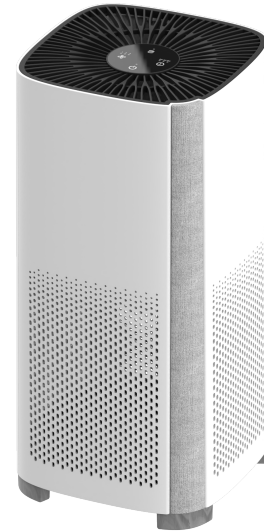

PLEASE READ AND SAVE THESE
INSTRUCTIONS FOR FUTURE REFERENCE

Model No: PF00-22380
Rev 01

IMPORTANT SAFETY INSTRUCTIONS:

When using electrical appliance. Basic safety precautions should always be followed including the following:

READ ALL INSTRUCTIONS BEFORE USE

- All components need to be installed in accordance with the user manual for correct performance of the unit.
- The use of accessory attachments not recommended by the appliance manufacturer may cause injuries.
- A unit should never be left unattended while plugged in.
- This appliance is not intended for use by persons (including children) with reduced physical, sensory or mental capabilities, or lack of experience and knowledge, unless they have been given supervision or instructions concerning use of the appliance by a person responsible for their safety.
- Children should be supervised to ensure that they do not play with the appliance.
- Do not operate any appliance with a damaged cord or plug or after the appliance malfunctions or has been damaged in any manner.
- If the supply cord is damaged, DO NOT use. For electrical safety, any repairs to the product should only be carried out by a qualified electrician only to avoid a hazard.
- Do not use appliance for other than intended use.
- For electrical safety, do not attempt to adjust or repair the unit. Servicing must be performed by a qualified electrical person only.
- DO NOT use outdoors. For indoor use only.
- Keep the rear air inlet and outlet free from blockages from clothing, plastic bags, paper or similar material. Proper air flow is required for the unit to operate efficiently.
- Place unit on a flat location at least 30cm away from wall or other appliances.
- Keep the unit away from fire, flammable gas, combustible products or vapours and corrosive substances.
- DO NOT operate the unit in bathrooms or other humid environments.
- DO NOT operate where aerosol (spray) products are being used, or where oxygen is being administered.
- Do not operate the unit without filters.
- Do not operate the product in any greasy environment, such as in the kitchen. This product is not intended to filter oil or grease from the air.
- Electrical supply must be disconnected prior to cleaning or other maintenance.
- NEVER drop or insert any object into any opening.
- DO NOT carry this unit by the power cord or use the power cord as a handle.
- For cleaning, please refer to "CLEANING AND MAINTENANCE" section.

CAUTION

- Never cover the unit while it is operating.
- Always keep the power cord away from high temperatures and fire.
- Stop using this unit if there is an unusual noise or smell.
- Unplug this unit when not in use for a long period of time.
- Do not run cord under carpeting. Do not cover cord with throw rugs, runners, or similar coverings. Arrange cord away from traffic areas and where it will not be tripped over.

**FOR HOUSEHOLD USE ONLY
READ AND SAVE THESE INSTRUCTIONS**

FEAUTES

3-Stage purification process

The 3-layer filter contains a Pre-filter, HEPA filter and activated carbon filter.

- The Pre-filter traps larger particles such as dust, pet hair and large-sized allergens.
- The HEPA filter (Grade H13) removes 99.9% of particles as small as 0.3 microns and greater from the air. It is capable to remove smoke, dust, pollen, pet dander and mould spores in the air.
- The Activated carbon filter absorbs common household odours, cigarette odours and smoke.

Fan speed options

Allow selection for desired speed setting: Low-1, Medium-2 and High-3.

Default setting at Speed-2.

Filter Replace indicator

RED indicator will illuminate indicating that the filter needs to be replaced.

To reset the indicator after the filter has been replaced, press and hold the Filter Replace button for 3 seconds.

Timer Setting

Programmable timer to turn off the unit after a pre-set amount of time.

Press the "TIMER SETTING" button to program the timer at 2hr, 4hr and 8hr.

IMPORTANT! Do not allow children to play with the air purifier.

PARTS

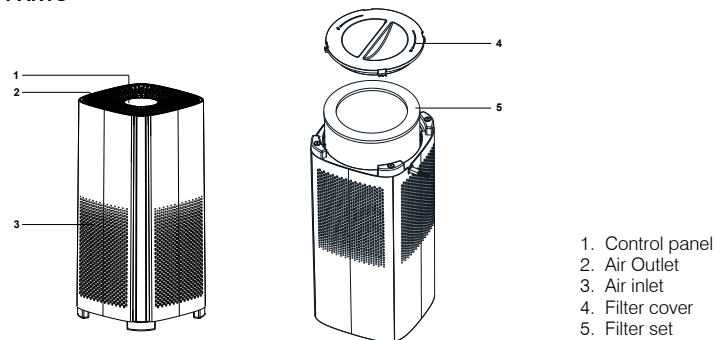

1. Control panel
2. Air Outlet
3. Air inlet
4. Filter cover
5. Filter set

Control panel

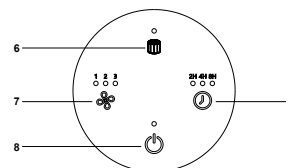

6. Filter Replace button
7. Fan speed button
8. Power On/Off button
9. Timer Setting button

Filter system

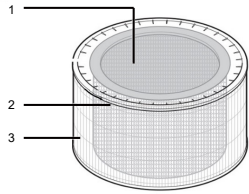

1. Activated carbon mesh
2. HEPA filter
3. Pre-filter mesh

HOW TO USE

IMPORTANT! Before first use, twist open the filter cover. Unwrap the filter set before installing in the unit.

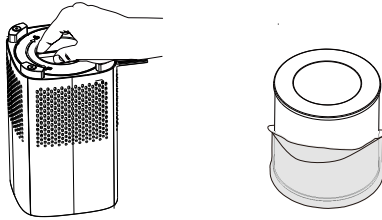

IMPORTANT! After placing the filter, ensure the filter cover is locked into place properly.

1. Plug unit in to a 220-240V AC electrical outlet. POWER button illuminates WHITE to show the unit is in standby mode.
2. Press the ON/OFF button to turn on the unit.
3. The air purifier default setting is at speed 2.
4. To select speed, press FAN SPEED button repeatedly until the desired fan speed indicator is illuminated on the control panel.
5. If auto off function is desired, press TIMER button until timer display indicator is illuminated on desired time 2/4/8 Hr.

CLEANING AND MAINTENANCE

CAUTION: Before cleaning, turn OFF and unplug the unit from mains power.

External cleaning of unit:

- Turn off and unplug the unit.
- Use a soft cloth slightly damp cloth and dishwashing soap to wipe the outer surfaces.
- Do not allow water to slip into the internal parts as this could damage the unit and result in electrical shock and injury.
- Allow the unit to dry thoroughly before use.

Cleaning the filter:

- Turn off and unplug the unit.
- Twist to open the filter cover located on the bottom of the unit, then pull out the filter.
- Run a vacuum cleaner with brush attachment on low power setting along the Pre-filter to pick up the dust and other particles.
- Re-attach filter and the filter cover.

IMPORTANT! When placing the filter back into the air purifier, ensure the air inlet grille is locked into place.

Note: It is recommended that the filters are cleaned every 100-500 hours of operation, depending on the air quality in the room and surroundings.

REPLACING THE FILTER

When the lifespan of the filter set reaches its end, discard the old filter and replace with a new one.

The lifespan and duration of the filter depends on the air quality in the surrounding environment. The higher level of pollutants, the shorter the filter lifespan. It is advisable to change the filter at 8-12 months or when Filter Replace indicator is illuminated.

How to replace filter

- Turn off and unplug the unit.
- Twist to open the filter cover then pull out the filter.
- Install a new filter in position, make sure the filter cover is locked into place.
- Press and hold the Filter Replace button for 3 seconds to reset the Filter Replace Indicator.

IMPORTANT! When placing the filters back into the air purifier, ensure the filter had locked into place properly.

SPECIFICATION

MODEL NO.	PF00-22380
VOLTAGE	220-240V
POWER CONSUMPTION	40 Watt
CLEAN AIR DELIVERY RATE	153m ³ /h
COVERAGE AREA	Up to 13m ²

TROUBLESHOOTING

Some problems may be caused by minor faults that you can be corrected yourself. To do so, follow the instructions in the following table. If it is still not possible to resolve the problem, contact Kmart customer service. Do not attempt to repair the air purifier yourself.

Problem	Possible cause	Solution
Power Light is off/ No power	<ul style="list-style-type: none">• Unit is not plugged in.• No power from the mains power outlet.	<ul style="list-style-type: none">• Plug the unit to mains supply, press the POWER ON/OFF button to turn on the unit.• Check circuits and fuses or try a different mains power outlet socket.
Reduced airflow or Poor filtering	<ul style="list-style-type: none">• Air inlet or outlet may be blocked• HPEA filter may be clogged	<ul style="list-style-type: none">• There must be at least 30cm between unit and wall or other appliances.• Remove any blockages that cover the air inlet/outlet.

12 Month Warranty

Thank you for your purchase from Kmart.

Kmart Australia Ltd warrants your new product to be free from defects in materials and workmanship for the period stated above, from the date of purchase, provided that the product is used in accordance with accompanying recommendations or instructions where provided. This warranty is in addition to your rights under the Australian Consumer Law.

Kmart will provide you with your choice of a refund, repair or exchange (where possible) for this product if it becomes defective within the warranty period. Kmart will bear the reasonable expense of claiming the warranty. This warranty will no longer apply where the defect is a result of alteration, accident, misuse, abuse or neglect.

Please retain your receipt as proof of purchase and contact our Customer Service Centre on 1800 124 125 (Australia) or 0800 945 995 (New Zealand) or alternatively, via Customer Help at Kmart.com.au for any difficulties with your product. Warranty claims and claims for expense incurred in returning this product can be addressed to our Customer Service Centre at 690 Springvale Rd, Mulgrave Vic 3170.

Our goods come with guarantees that cannot be excluded under the Australian Consumer Law. You are entitled to a replacement or refund for a major failure and compensation for any other reasonably foreseeable loss or damage. You are also entitled to have the goods repaired or replaced if the goods fail to be of acceptable quality and the failure does not amount to a major failure.

For New Zealand customers, this warranty is in addition to statutory rights observed under New Zealand legislation.