

## 12 month warranty

Thank you for your purchase from Kmart.

Kmart Australia Ltd warrants your new product to be free from defects in materials and workmanship for the period stated above, from the date of purchase, provided that the product is used in accordance with the accompanying recommendations or instructions where provided. This warranty is in addition to your rights under the Australian Consumer Law.

Kmart will provide you with your choice of a refund, repair or exchange (where possible) for this product if it becomes defective within the warranty period. Kmart will bear the reasonable expense of claiming the warranty. This warranty will no longer apply where the defect is a result of alteration, accident, misuse, abuse or neglect.

Please retain your receipt as proof of purchase and contact our Customer Service Centre on **1800 124 125 (Australia)** or **0800 945 995 (New Zealand)** or alternatively, via Customer Help at [kmart.com.au](http://kmart.com.au) for any difficulties with your product. Warranty claims and claims for expense incurred in returning this product can be addressed to our Customer Service Centre at 690 Springvale Rd, Mulgrave Vic 3170.

Our goods come with guarantees that cannot be excluded under the Australian Consumer Law. You are entitled to a replacement or refund for a major failure and compensation for any other reasonably foreseeable loss or damage. You are also entitled to have the goods repaired or replaced if the goods fail to be of acceptable quality and the failure does not amount to a major failure.

For New Zealand customers, this warranty is in addition to statutory rights observed under New Zealand legislation.

### Statement

- High or low extreme temperatures that a battery cannot be subjected to during use, storage or transportation and low air pressure at high altitude.
  - Replacement of battery with an incorrect type that can defeat a safeguard
  - Disposal of a battery into fire or a hot oven, or mechanically crushing or cutting of a battery, that can result in an explosion.
  - Leaving battery in an extremely high temperature surrounding environment that can result in an explosion or the leakage of flammable liquid of or gas
  - A battery subjected to in an extremely low air pressure that can result in an explosion or the leakage of flammable liquid of or gas
  - CAUTION: Risk of explosion if the battery is replaced by an incorrect type
- This Bluetooth earbuds shall be charged by the supplied charging unit only.

**WARNING** Do not dispose of unit in fire or water. › Never attempt to disassemble and reassemble. › Waste electrical products should not be disposed of with household waste, please recycle where facilities exist. › Check with your local authority for recycle advice. › Keep your device and all accessories out of the reach of children and animals. › Small parts may cause choking or serious injury if swallowed. › Avoid exposing your device to very cold or very hot temperatures (below 0°C or above 30°C). › Extreme temperatures can cause deforming of the device and reduce the charging capacity and life of your device. › Do not allow your device to get wet—liquids can cause serious damage. › Do not handle your device with wet hands.

# Bluetooth® earphones Operating instructions

includes:

- › Bluetooth earphones
- › Charging cable
- › Use manual
- › Silicone caps

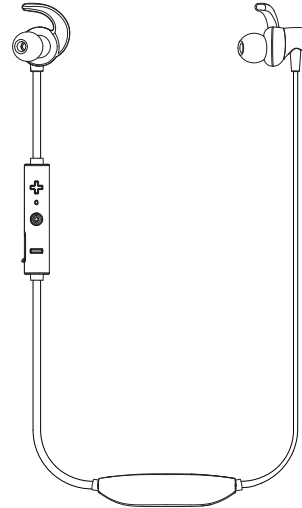

## Function overview:

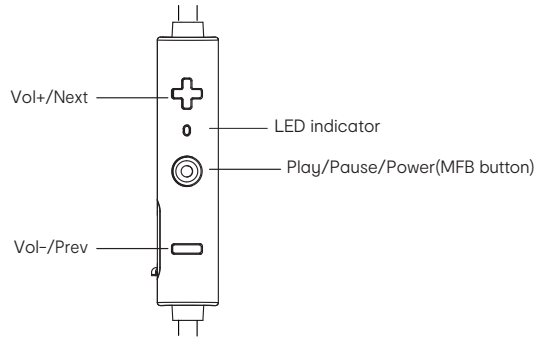

## How to use these earphones:

### Function Operation

**Pause** click  $\odot$  button

**Play** click  $\odot$  button

**Next** Song press and hold + button

**Previous** Song press and hold - button

**Volume Up** click + button - when the volume is adjusted to maximum you will hear a tone notification

**Volume Down** click - button

### Power ON / OFF

#### Power ON

Press and hold power button  $\odot$  3s. You will hear a voice indication tone

#### Power OFF

Press and hold power button  $\odot$  4s. You will hear a voice indication tone

## Specifications:

**Model No:**  
43241491

**Version:**  
V5.0

**Support profiles:**  
A2DP, AVRCP, HFP

**Working Distance:**  
10 meters

**Music Time:**  
8 Hours

**Talk time:**  
6 Hours

**Standby time:**  
>100 Hours

**Charging voltage:**  
5V d.c.

**Charge time:**  
2.5 Hours

**Pairing window time:**  
10 minutes

## Pairing the earphone with Bluetooth devices

- Once the earphone is powered on, it is in pairing mode (LED flashes) and will pair to the last paired device (if available).
- Pair the earphone in Bluetooth menu in mobile phone and once it is paired, you can hear a pairing tone and the LED will off.  
Bluetooth Name: KM43241491

## Phone calls

- Press  $\odot$  button to pick up/hang up phone calls.

Press and hold the  $\odot$  2S reject the calls

Note:

There is a vibration reminder function for incoming calls

## Playing music

When the earphone connects with the mobile phone via Bluetooth you can enjoy music through the earphone earphonewirelessly.

## Battery Charging

This Bluetooth earphone is powered by rechargeable Li-ion battery.

Please use the accessory USB cable to recharge the battery.

- Insert USB charging cable into a suitable USB port.
- Connect charging cable with the headset USB port.
- Indicator LED turns RED to show battery is charging.
- Indicator LED turns off when battery is fully charged.
- It takes about 2.5 hours to fully charge the battery.

The Bluetooth® word mark and logos are registered trademarks owned by Bluetooth® SIG, Inc., and any use of such marks by KMART AUSTRALIA is under licence.

## Statement

- This product shall not be connected to power supply source exceeding PS1 (5V d.c. 1A).
- Battery cannot be subjected to high or low extreme temperatures, low air pressure at high altitude during use, storage or transportation.
- Replacement of a battery with an incorrect type that can result in an explosion or the leakage of flammable liquid or gas.
- Disposal of a battery into fire or a hot oven, or mechanically crushing or cutting of a battery, that can result in an explosion.
- Leaving a battery in an extremely high temperature surrounding environment that can result in an explosion or the leakage of flammable liquid or gas.
- A battery subjected to extremely low air pressure that may result in an explosion or the leakage of flammable liquid or gas.
- The apparatus is only suitable for mounting at height < 2m.