

anko

Rechargeable Hand - Stick Vac For Household Use Only

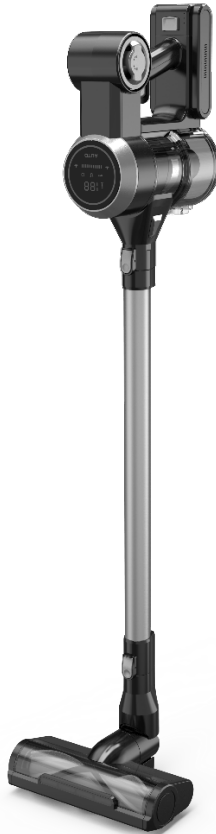

Model No.: EV-6803-S259
Rev 5

Note: The specifications and/or components of this appliance are subject to change without prior notice.

If any Accessories should fail during use, please call 1300 105 888 (Australia) or 09 8870 447 (New Zealand) for an immediate replacement. This will save you from returning the product to the store.

If we can assist you in any other way, please feel free to contact us.

1	Warnings	4
2	Safety Directions	4
3	Transporting your Vacuum	7
4	Components	7
4.1	Introduction to the Control Panel	8
5	Assembly Method	8
5.1	Attaching and removal of Battery Pack	8
5.2	Attaching the Extension Tube	9
5.3	Removing the Extension Tube	9
5.4	Attaching the Motorised Floor Head	10
5.5	Removing the Motorised Floor Head	10
5.6	Using Without the Extension Tube	10
5.7	Tools	11
5.8	Charging	11
5.9	When to Charge Indicator	13
6	Antistatic Contacts	13
7	Using the Vacuum Cleaner	14
7.1	On / Off	14
7.2	Speed Control	14
7.2.1	Default Mode - Auto	14
7.2.2	Manual Mode	15
7.2.3	Auto Mode	15
8	Indicator Lights	16
8.1	Jammed Floor Head Brush	16
8.2	Filter Blockage / Air Flow Blockage	16
8.3	Dust Indicator	17
8.4	Battery Overheating	17
9	Emptying the Dust Canister	18
10	User Maintenance	18
10.1	Cleaning the Main Filters	18
10.2	Exhaust Filter	20
10.3	Cleaning Dust Canister	21
10.4	Cleaning the Vacuum Cleaner Body and Tools	22
10.5	Cleaning the Motorised Floor Head	22
11	Storage	24
11.1	Wall Mount Storage / Charging	24
11.2	Vacuum Cleaner / Tool	24
12	Troubleshooting	26
14	Warranty Against Defect	28

1 Warnings

Before using this appliance, read and follow all warnings and instructions in this manual, even if you are familiar with this product.

This appliance is not intended for use by persons (including children) with reduced physical, sensory or mental capabilities, or lack of experience and knowledge unless they have been given supervision or instruction concerning the use of the appliance by a person responsible for their safety.

Children should be supervised to ensure that they do not play with the appliance.

2 Safety Directions



Please read this instruction manual carefully before first use. It is advisable to keep this instruction manual for future reference.



For indoor use only.

DO NOT vacuum water, wet objects, liquids, ashes, hot coals, cigarette butts, matches or any hot, smoking or burning objects etc.

DO NOT pick up flammable or combustible materials (i.e., lighter fluid, petrol, kerosene, etc.) or use in the presence of explosive liquids or vapour.

DO NOT pick up toxic material (i.e., chlorine bleach, ammonia, drain cleaner, etc.)

DO NOT vacuum Toner (for laser printers, copy machines etc.) as there is a risk of fire and explosion.

DO NOT vacuum plaster dust, cement dust etc. as the filter will block very quickly.

DO NOT use the vacuum without the filter fitted.

DO NOT store or use the appliance near high-temperature areas.

DO NOT run over the charger cable with the vacuum cleaner.

DO NOT use the vacuum cleaner if it is blocked. Turn off and clear all blockages before continuing.

DO NOT use the vacuum cleaner with a blocked filter. Clean the filter before continuing. (refer to User Maintenance section).

DO NOT use the vacuum cleaner if the appliance malfunctions, abnormal noise, smells, or smoke, is dropped or damaged in any manner or if any breakage is found during the operation.

For electrical safety, any repairs to the product must be performed by a qualified electrical person only, or the product must be disposed of.

DO NOT misuse the Charger Cable. Never pull the appliance by the cable or pull to disconnect it from the outlet. Instead, grasp the charger body and pull to disconnect.

DO NOT use the vacuum cleaner to pick up large objects, hard or sharp objects such as glass, nails, screws, coins, etc. that are likely to cause damage.

DO NOT use with damaged Charger Cable or Charger Body.

DO NOT use the vacuum cleaner if it has been dropped, damaged, left outdoors, or dropped into liquid (water etc.)

DO NOT handle the Charger or vacuum cleaner with wet hands.

DO NOT put any objects into openings.

DO NOT use with any openings blocked and do not restrict airflow.

DO NOT use without the filter in place.

DO NOT attempt to modify this product in any way.

DO empty the Dust Canister regularly for optimal operation of the vacuum.

DO keep hair, loose clothing, fingers, feet and body parts away from openings or moving parts.

DO disconnect the Charger from the power supply when not in use,

DO use only on dry, indoor surfaces.

DO use only as described in this manual. Use only the manufacturer's recommended attachments.

DO Keep the Charger Cable away from heated surfaces.

DO Keep all openings free of dust, lint, hair, and anything that may reduce airflow.

DO use extra care when vacuuming on stairs.

DO keep your work area well-lit.

DO store your appliance indoors in a cool dry area.

DO ensure children and babies cannot play with plastic bags or any packaging materials.

DO operate the Charger from a power source of the same voltage, frequency and rating as indicated on the product identification plate.



WARNING

Only use the Battery Charger which was supplied with this appliance.
Model No. ZD12D300050AU 100–240V~ 50/60Hz 0.5A Output: 30.0V --- 500mA

 The battery charger is detachable.

Battery Pack Specification: EV-6803 Type: Li-ion, 25.9Vd.c., 2200mAh

Consumers are cautioned against using and/or purchasing counterfeit and/or inferior-quality batteries. These batteries have the potential to cause fire, personal injury, and/or damage to property. These batteries are typically found on online auction websites or from other retailers and are known to pose a potential safety risk.

This appliance contains Non-replaceable batteries.

Never try to recharge Non-Rechargeable batteries as they may explode, catch on fire or cause personal injury and/or damage to property.

- May explode if disposed of in fire.
- To prevent injury or burns, do not allow metal objects to contact battery terminals.
- Do not use or store in temperatures above 40°C.



The Battery Pack must be removed from the vacuum cleaner before disposal.

Contact your local waste management authority for more information on Battery Recycling and disposal regulations in your area.



This symbol on the product or its packaging indicates:

Do not dispose of electrical appliances or batteries as unsorted municipal waste, use separate collection facilities. Contact your local council for information regarding the collection systems available. If electrical appliances are disposed of in landfills or dumps, hazardous substances can leak into the groundwater and get into the food chain, damaging your health and well-being. Please contact your local council or regional authority for more information on the collection, reuse, and recycling programmes.

If this appliance is used by a third party, **DO** supply the instruction manual with it.

No liability can be accepted for any damage caused by non-compliance with these instructions or any other improper use or mishandling of the appliance.

This product has not been designed for any uses other than those specified in this manual.

ONLY for domestic use. Industrial or commercial use invalidates the warranty.

Read and Save These Instructions

3 Transporting your Vacuum

To move your vacuum cleaner from room to room, unplug the unit and carry using the carry handle.

Never pull or carry the vacuum cleaner by its Charger cable.

Never carry the vacuum cleaner with the accessories / Tools.

4 Components

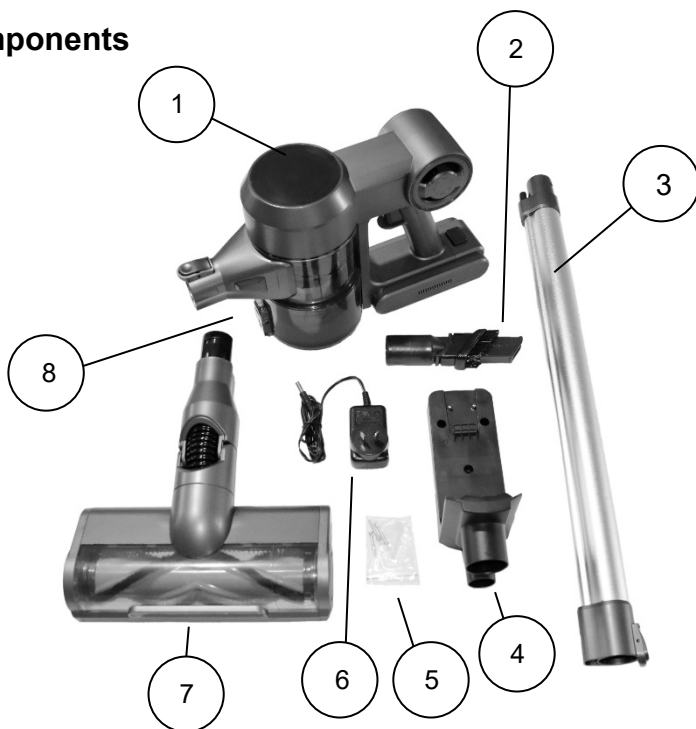

1	Control Panel / Rechargeable Battery Pack	5	Wall Mount Plugs and Screws
2	Crevice / Brush Tool	6	Battery Charger - ZD12D300050AU
3	Extension Tube	7	Motorised Floor Head
4	Wall Mount / Tool Holder Bracket	8	Dust Canister

Note: The specifications and/or components of this appliance are subject to change without prior notice

4.1 Introduction to the Control Panel

Note: Refer to individual sections in this manual for detailed information.

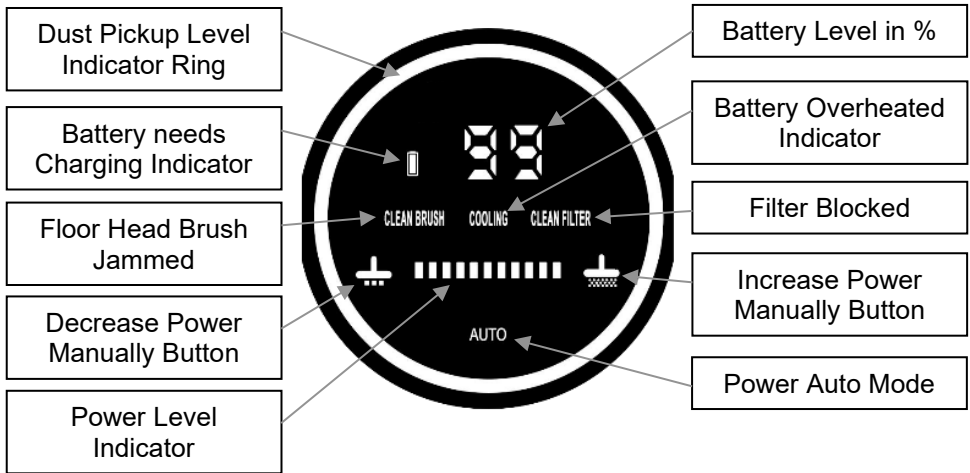

5 Assembly Method

5.1 Attaching and removal of Battery Pack

Note: Charge the Vacuum Cleaner for at least 5 hours x 2 times before first use.

Only use the Battery Charger which was supplied with this appliance.

Slide the battery pack onto the bottom of the vacuum cleaner handle and push all the way in until it locks in place as shown:

Note: The Battery can only be fitted in one direction.



There should be no need to remove the battery pack once fitted, however, if you should need to remove it, press the release button located on the top of the battery pack, and at the same time, slide the battery straight out.

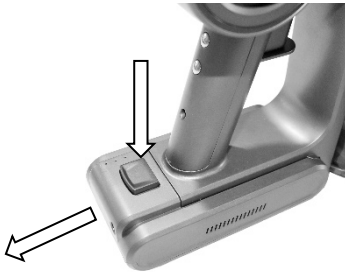

5.2 Attaching the Extension Tube

Insert the top end of the Extension Tube into the mating hole in the vacuum cleaner body ensuring the locking tabs are aligned, then push inward until it locks into place.

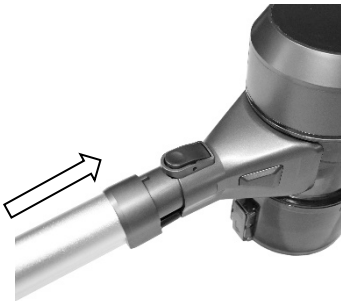

5.3 Removing the Extension Tube

To remove the Extension Tube, press the locking button to release then pull the tube straight out.

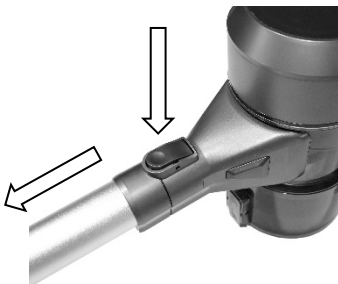

5.4 Attaching the Motorised Floor Head

To attach the motorised floor head to the other end of the extension tube, insert the end of the Extension Tube into the end of the Floor Head, ensuring the locking tabs are aligned, then push inward until it locks into place.

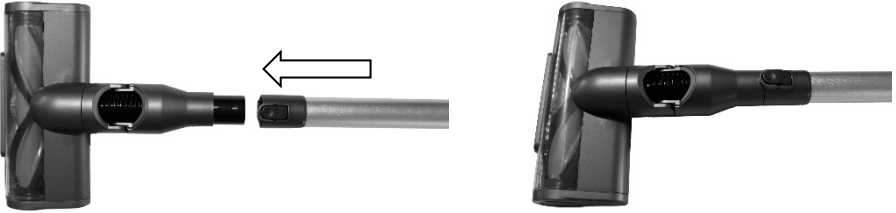

5.5 Removing the Motorised Floor Head

To remove the Motorised Floor Head, grasp the Motorised Floor Head, press the locking button to release it, and then pull the tube straight up and out.



5.6 Using Without the Extension Tube.

The vacuum cleaner can be used without the extension tube by attaching the Accessories and Motorised Floor Head directly to the vacuum cleaner.

To attach and remove, follow the same steps as if using the Extension tube.

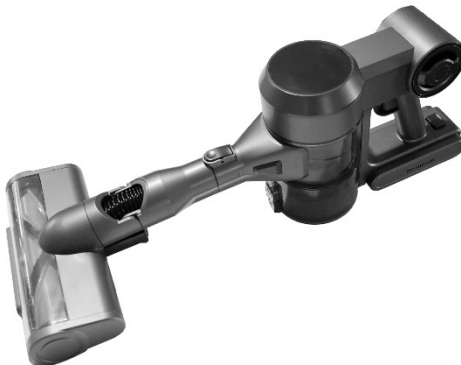

5.7 Tools

The Crevice / Brush tool is for cleaning furniture and into corners etc.

To use the Brush tool, press the release button to unlatch and slide the brush down until it locks in place.

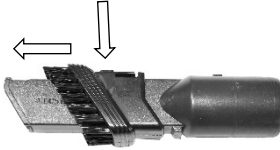

To use the Crevice tool, press the release button to unlatch and slide the brush up until it locks in place.

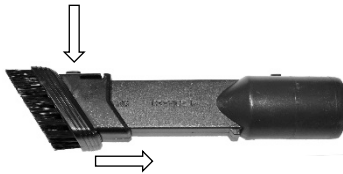

To fit the tool, line up with the end of the hand vac and push in.

Note: The tool can also be used on the end of the Extension Tube.

To remove, press the locking button to release and then pull the tool straight out.

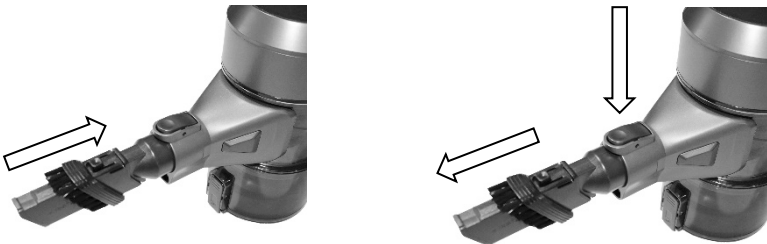

5.8 Charging

The battery can be charged whilst the whole vacuum cleaner is stowed on the wall hanging bracket or the battery can be charged separately.

Note: Refer to the section “Storage” for instructions on mounting the Storage Bracket to the wall.

For the wall hanging bracket: insert the small plug end of the battery charger into the socket of the wall hanging bracket as shown.

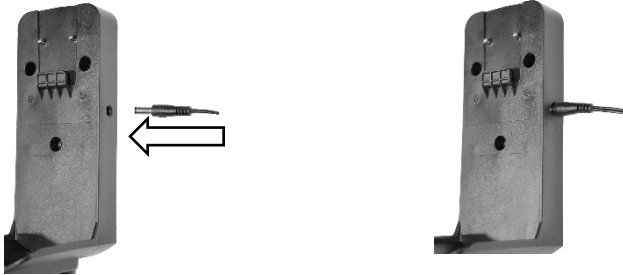

For charging the battery directly without the wall hanging bracket: insert the small plug end of the battery charger into the socket of the battery as shown.



Plug the Battery Charger into the power point and switch on.

During Charging, the digital readout will display the percentage of charge and the amount of LED dots on the battery will blink also displaying the amount of charge as well as indicating that the battery is charging.

The digital readout will show 100% when fully charged.

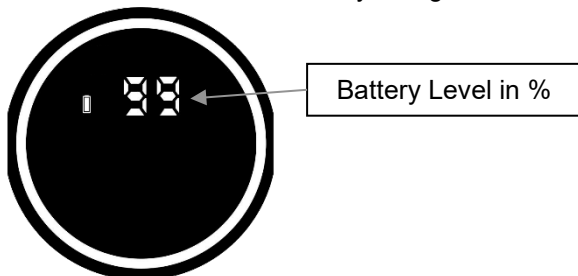

When the battery is fully charged, switch off and unplug the battery charger from the power supply and from the battery.

When fully charged, the Vacuum Cleaner is ready for use.

IMPORTANT: NEVER BLOCK ANY VENTS OR OPENINGS OR COVER THE UNIT WHILE CHARGING.

5.9 When to Charge Indicator

During use, if the battery level decreases to approximately 10% remaining power, the small battery icon will turn Red colour indicating that the battery needs to be recharged.

When the battery power level is above 10%, this indicator will change to a White colour.

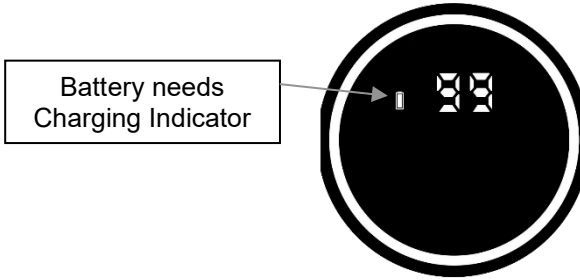

6 Antistatic Contacts

There are two contacts located on the back of the handle.

These contacts will touch your hand during use and will help illuminate the static build-up in the vacuum cleaner, and thus, helps prevent you from getting a static shock if used on synthetic carpets and surfaces.

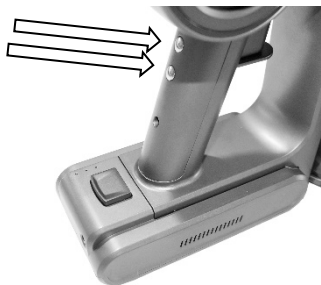

7 Using the Vacuum Cleaner

7.1 On / Off

To use the Vacuum Cleaner, assemble the unit as previously instructed and ensure the battery is fully charged.

To switch on, grasp the handle and squeeze the trigger on the handle.



The vacuum cleaner will start in the default power mode (Auto).

Release the trigger to turn off.

Note: The vacuum cleaner cannot be started when charging.

7.2 Speed Control

7.2.1 Default Mode - Auto



When the vacuum cleaner is first switched on for use, it will default to the “Auto” mode setting as indicated by the word “Auto” and the Symbol illuminating in white colour on the control display. This will remain on this setting unless manually changed.

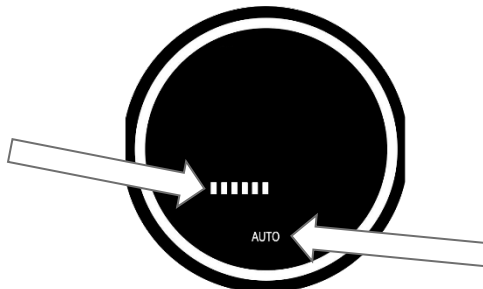

The power setting will be displayed by the illuminated bars.



During use in Auto mode, depending on the floor surface and the amount of dust the vacuum cleaner is picking up, the vacuum cleaner suction will automatically adjust to the required power.

7.2.2 Manual Mode

Whilst the vacuum cleaner is running, press either the  Button to reduce power or the  Button to Increase Power. The word "Auto" will turn Red colour indicating you are in Manual Mode.

Note: Each press of the  button or  button will step to the next power setting. There are 5 power levels.

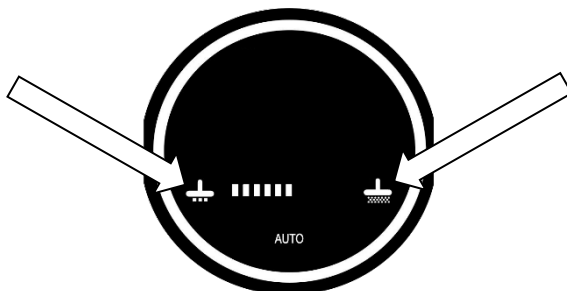

Note: Using Maximum Power will use the battery power quicker than in the Default Mode setting.

7.2.3 Auto Mode

Whilst the vacuum cleaner is running in Manual Mode, press on the word "Auto" on the control panel once.

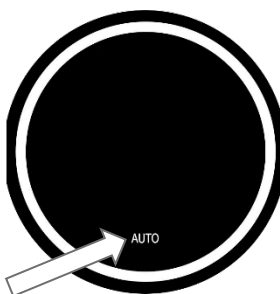

The vacuum cleaner will change to "Auto" power mode and the word "Auto" will illuminate in white colour indicating it is in "Auto" mode.

8 Indicator Lights

8.1 Jammed Floor Head Brush

The vacuum cleaner is fitted with a sensor that detects if the floor head rotary brush gets jammed.

If the brush gets jammed, the Floor Head will turn off and the words “**CLEAN BRUSH**” in red text on the control panel will blink on and off.

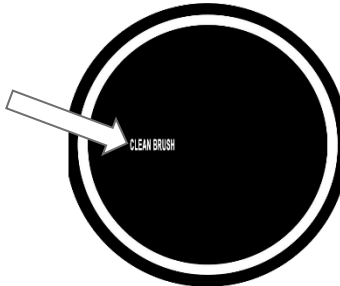

Note: The vacuum suction motor will continue to run, therefore; switch off the vacuum cleaner and refer to the “Cleaning the Motorised Floor Head” section in this manual on how to clear a floor head jam.

8.2 Filter Blockage / Air Flow Blockage

The vacuum cleaner is fitted with a sensor that detects if the filter is severely blocked or if there is an airflow blockage.

If the filter becomes severely blocked, or if there is an airflow blockage, the words “**CLEAN FILTER**” in red text on the control panel will blink on and off.

Important: If this happens, it is very important to turn the vacuum cleaner off before it overheats.

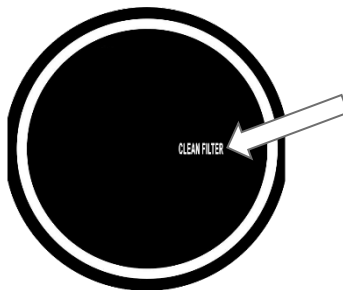

Check for blockages in the floor head and tubes etc. If no blockages are found, clean or replace the filter.

Refer to the “Cleaning the Filter” section in this manual on how to clean or replace the main filter.

If the vacuum cleaner has overheated and turned off, after checking for blockages and after cleaning the filters, allow the vacuum cleaner to cool down for 1 hour before using again.

8.3 Dust Indicator

The ring around the display will illuminate in a clockwise direction visually indicating how much dust and debris is being picked up.

Blue colour means a small amount of dust and Red colour means a lot of dust is being picked up.

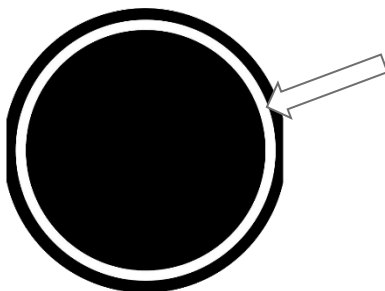

8.4 Battery Overheating

The vacuum cleaner is fitted with a sensor that monitors the battery temperature.

If the battery should overheat during charging or use, the word “**COOLING**” in red text on the control panel will blink on and off, and shortly afterwards, the vacuum cleaner will turn off.

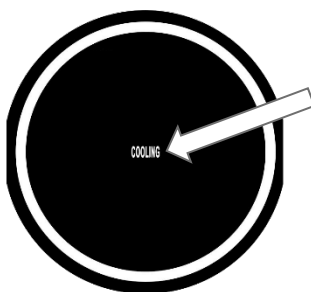

If this should happen, unplug the battery charger (if charging) and allow the vacuum cleaner to cool down for at least 1 hour before attempting to start again.

Note: If charging or using in a hot environment (+40°C), there is more chance of the battery overheating.

9 Emptying the Dust Canister

To Empty the dust canister, take the vacuum cleaner to a dustbin.

Press the release button on the dust canister and the trap door will swing open emptying the contents into the bin.



To close the trap door, close it manually until it clips shut.

Empty the Dust Canister as frequently as possible or when the suction power is reduced or after use for optimum performance.

10 User Maintenance

WARNING: The battery must be removed from the vacuum cleaner before any maintenance, cleaning or replacement of parts.

NOTE: To maximise the performance of your vacuum cleaner, you should clean the filters regularly.

If the filter is broken or worn, replace it before continuing to use the vacuum.

A new filter can be purchased from our Customer Service. You can call our customer service number: 1300 105 888 (Australia) and 09 8870 447 (New Zealand), or via email info@hegroup.com.au

10.1 Cleaning the Main Filters

Important Note – The Filters must be cleaned regularly for the best suction performance and to prevent overheating and damage to your vacuum cleaner.

Cleaning is best done at the same time when emptying the dust Canister after you have finished vacuuming for the day.

NOTE: Never use the vacuum cleaner with a wet or damp filter or without the filter fitted.

Using a wet or damp filter will damage the filter, may cause serious damage to the vacuum cleaner and will void your warranty.

Only wash the filter if it is very dirty, otherwise, just tap the edge of the filter on a hard surface to dislodge any dust and debris.

To access the filter, first, remove the base of the dust canister by grasping the base of the dust canister with one hand, and while holding the vacuum cleaner body with the other hand, rotate the base to the left and then pull down and away.

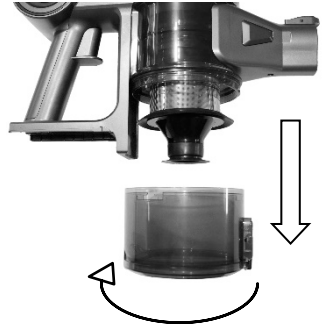

Grasp the filter and pull it straight down to remove it.



Grasp the Ribbon on top of the white filter and pull it straight up and away.

Remove the foam black filter.



Only wash the white filter if it is very dirty, otherwise, just tap the edge of the filter on a hard surface to dislodge any dust and debris.

The black foam filter can just be tapped clean. Do not wash.

If needed, wash the white filter and filter holder in warm mild soapy water, rinse them in clean fresh cold water and let them completely dry.

DO NOT scrub the filter or filter holder or place them in a dishwasher.

DO NOT use a hairdryer to dry the white filter or filter holder.

Refit the black foam filter to the filter holder and then refit the white filter (or replace it with a new one) in the reverse method used for disassembly.

10.2 Exhaust Filter

The filter which filters the exhaust air is a HEPA filter and needs to be cleaned (or replaced) regularly for the best suction performance and to prevent overheating and damage to your vacuum cleaner.

The filter is located above the handle and on the left side where the exhaust air exits.

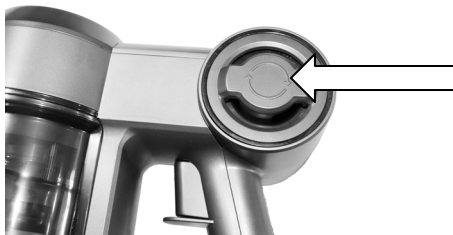

To access the filter, rotate the cover anticlockwise and pull away to expose the filter.

Grasp the filter and pull it straight out.



Only wash the filter if it is very dirty, otherwise, just tap the edge of the filter on a hard surface to dislodge any dust and debris.

If needed, wash the filter in warm mild soapy water, rinse in clean fresh cold water and let them completely dry.

DO NOT scrub the filter or place it in a dishwasher.

DO NOT use a hairdryer to dry the filter.

Refit the filter (or replace it with a new one every 6 months) in the reverse method used for disassembly.

10.3 Cleaning Dust Canister

Remove the dust canister base as described previously and remove the filter and filter holder as described previously.

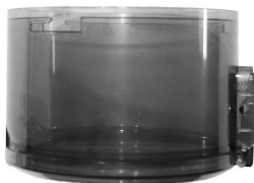

Wash the dust canister base in warm mild soapy water, rinse in clean fresh cold water and let completely dry.

DO NOT scrub the dust canister or place it in a dishwasher.

DO NOT use a hairdryer to dry the dust canister.

Note: For the upper part of the dust canister, which is attached to the vacuum cleaner, just brush it out and wipe it over with a moist cloth with mild detergent, then dry it off.

Reassemble and Refit in the reverse method used for disassembly.

Align the arrow and padlock symbols on the side of the dust canister sections then rotate to lock in place.



10.4 Cleaning the Vacuum Cleaner Body and Tools

Do not clean the vacuum cleaner, components or accessories using petrol or any other flammable liquid or solvents, etc.

Clean only the outside of the vacuum cleaner.

Use only a moist cloth and mild detergent for cleaning the vacuum cleaner, components and accessories.

After cleaning, wipe off the moisture on the vacuum cleaner, components and accessories with a dry cloth.

Do Not place accessories / components in a dishwasher.

10.5 Cleaning the Motorised Floor Head

The Rotary Brush in the floor head can be removed for easy cleaning and removal of hair etc.

Ensure the Floor Head is removed from the extension tube or vacuum cleaner first.

Turn over so that the bottom face is facing up.

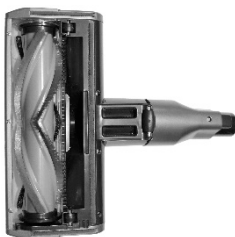

There is a small tab on the bottom that needs to be slid upward to unlock the Rotary Brush Holder and which will pop up.

When unlatched, grasp the rotary brush and lift it up while sliding to the right and lift out.

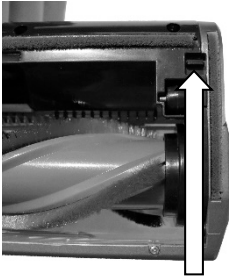

Remove any hair, thread, debris, etc. that may have caught around the brush, end bearings, wheels or stuck in the openings.

After cleaning, refit the brush in reverse order to disassembling it.

Note: The brush can only be fitted in one direction as follows.

Align the end of the brush onto its drive spindle and rotate the brush until it slides down onto the spindle, then push down on the brush until it is located in position.

Swing the Rotary Brush Holder back over and push down until the brush assembly locks in place.



11 Storage

11.1 Wall Mount Storage / Charging

There is a Storage / Charging Bracket with a Tool Holder supplied with screws and wall plugs should you prefer to hang the vacuum cleaner on the wall.

To install the Storage / Charging Bracket, position the Storage / Charging Bracket on the wall, near a power point and at a suitable height where the vacuum cleaner will not touch the floor.

Mark the screw holes through the Storage / Charging Bracket onto the wall.

Using a suitable drill (wood drill bit for a timber wall, or masonry drill bit for brick / concrete walls, drill holes Ø6mm and 35 - 40mm deep.

Insert the plastic wall plugs into each hole and gently hammer in until they are flush with the wall, place the Storage Bracket over the holes then insert the screws and tighten up. Do Not Overtighten.

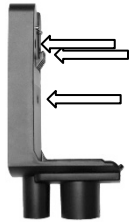

11.2 Vacuum Cleaner / Tool

When finished using the vacuum cleaner, empty the dust canister and clean the filters.

You can either recharge the battery first or store it away in a dry cool place.

Switch off and unplug the battery charger when not in use, or when fully charged.

Store the Tool on the wall mount bracket as shown.



Push the tool onto the holder until it locks in place.

To release the tool, pull the tool straight down and out.

Hang the vacuum cleaner as shown:

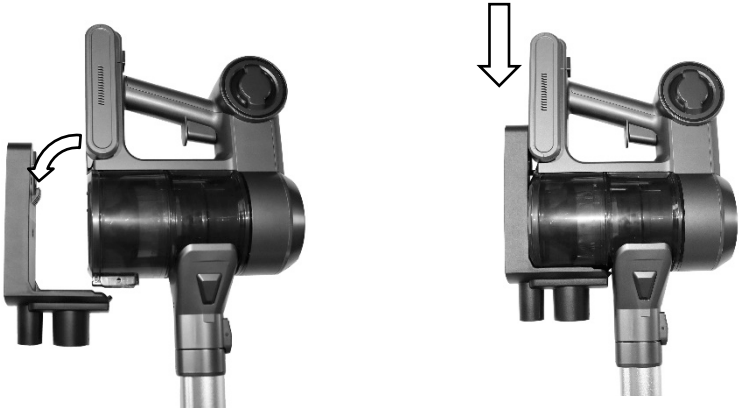

12 Troubleshooting

Will Not Switch On	Check that the battery is fully charged and inserted correctly.
	The Motor or Battery has overheated. Allow to cool for at least 1 hour.
The floor Head turned off and the red text CLEAN BRUSH flashing	The floor Head brush is jammed. Ensure the Vacuum Cleaner is switched off and the battery is removed then remove the debris from the brush.
Red text CLEAN FILTER flashing	Clean the filter and empty the Dust Canister. Check for blockages and unblock. Please call 1300 105 888 to order a new Filter or Battery.
The Vacuum Cleaner turned off and the red text COOLING flashing	The battery has overheated. Do not charge or use in temperatures 40°C and above. Unplug the battery charger (if charging) and allow the vacuum cleaner to cool down for at least 1 hour before attempting to start again
Noisy operation	Clean the main filter and empty the Dust Canister
	Check for partial blockages and unblock.
Suction Not Strong	Clean the exhaust filter and main filter and empty the Dust Canister. Check for blockages and unblock. Check that the battery is fully charged. Please call 1300 105 888 to order a new Filter or Battery.
	Speed setting may only be set to Low. Press the "Increase Power" Button to select the Highest power mode.
Floor Head hard to push	The Rotary Brush in the floor head may be jammed with debris etc. Ensure the Vacuum Cleaner is switched off and the battery is removed then remove the debris from the brush. Or the carpet pile may be too long.
Static Shock	In some rare instances, one or two users may feel an electric discharge when touching or using the vacuum cleaner during or after use. This is a well know phenomenon of Static Electricity discharge that happens mostly when the user vacuums a synthetic fibre carpet or other synthetic surfaces. It can also be more prevalent in dry and cool environments. Although the feeling of Static Electricity can be unpleasant for the user, it is not dangerous and is not a fault of the vacuum cleaner. If this static discharge is a problem for the user, the user could try wearing insulating footwear during vacuuming (i.e., rubber or leather soles) or increase the humidity / heat level in the surrounding environment or both.

14 Warranty Against Defect

12 Month Warranty

Thank you for your purchase.

Your new product is warranted to be free from defects in materials and workmanship for the period stated above, from the date of purchase, provided that the product is used in accordance with accompanying recommendations or instructions where provided. This warranty is in addition to your rights under the Australian Consumer Law. For New Zealand customers, this warranty is in addition to statutory rights observed under New Zealand legislation.

We will provide you with your choice of a refund, repair (where possible) or exchange (availability dependent) for this product if it becomes defective within the warranty period. The business will bear the reasonable expense of claiming the warranty. This warranty will no longer apply where the defect is a result of alteration, accident, misuse, abuse or neglect.

Please retain your receipt as proof of purchase and contact our Customer Service Centre as listed below, for the entity you purchased this product from, for any difficulties with your product. Warranty claims and claims for expenses incurred in returning this product can be addressed to the respective Customer Service Centre.

Our goods come with guarantees that cannot be excluded under the Australian Consumer Law. You are entitled to a replacement or refund for a major failure and compensation for any other reasonably foreseeable loss or damage. You are also entitled to have the goods repaired or replaced if the goods fail to be of acceptable quality and the failure does not amount to a major failure.

Contact for Kmart purchases	Contact for Target purchases
Kmart Australia Ltd. C/- Customer Service Centre, 690 Springvale Road, Mulgrave Vic 3170 Customer Service: 1800 124 125 (Australia) or 0800 945 995 (New Zealand) or via Customer Help at kmart.com.au	Target Australia Pty Ltd. C/- Customer Service Centre, 2 Kendall Street, Williams Landing, Vic, 3027 Customer Service: 1300 753 567 or via Customer Help at target.com.au/help/contact-us

IMPORTANT! For all technical queries or difficulties in operating the product and for spare parts, contact H.E. Group customer service 1300 105 888 (Australia) and 09 8870 447 (New Zealand).

