

100mm
100mm
100mm
100mm
100mm

110mm

**K: 43174928 | T: 68765057**  
**WATERLESS OIL DIFFUSER**  
**Instruction Manual**

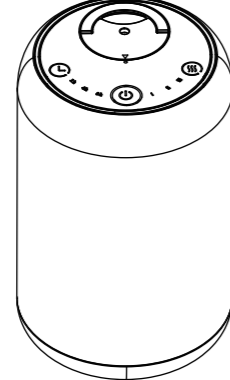

This waterless essential oil diffuser adopts cold diffusion technology, converting essential oil into micro vapor without heat and water.

**IMPORTANT!**  
Care should be taken with the use of diffusers around animals. Both the choice of essential oils and where animals are should be taken into consideration when in use.

**Attention**

- Do not use as a medical respirator.
- Do not use the product when there is an abnormal noise or the diffuser is overheating abnormally.
- Do not cover or block the mist outlet or air inlet.
- Do not take off the cover during operation of the diffuser.
- Do not place near an electric device such as a computer, TV or audio equipment.
- Keep out reach of children and animals.

**Warning**

- Important safety instructions: The following safety precautions should always be followed, to reduce the risk of electric shock, personal injury or fire. It is important to read all of these instructions carefully before using the product, and to save them for future reference or new users.
- This appliance is not intended for use by persons (including children) with reduced physical, sensory or mental capabilities, or lack of experience and knowledge, unless they have been given supervision or instruction concerning use of the appliance by a person responsible for their safety.
- Children should be supervised to ensure that they do not play with the appliance.
- Only to be used with 100% essential oils, other solutions may be toxic or create a fire risk.
- For charging, please refer to "Charging the diffuser" section.
- This appliance contains batteries that are non-replaceable.

**Includes**

Main Unit / USB cord: 5Vd.c.

**Names of parts**

- Mist Nozzle
- Charging Indicator
- Ambient Light
- Mist Intensity Indicator
- Mist Button
- Essential Oil Bottle
- USB Charging Port
- Power Button
- Timer Indicator
- Timer Button
- USB Charging Cable
- Cap Opener

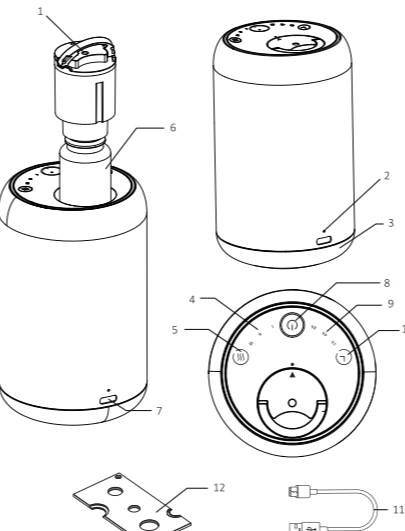

**Power, Mist and Timer Buttons**

**Power button:**

- Hold for 1.5 seconds, the unit will spray for 60 seconds and stop for 120 seconds with RGB changing mode and timer on for 1 hour
- Hold for 1.5 seconds, turn off the unit.

**Note:**  
The diffuser will recall the last setting when turned back on and restore to factory settings after the battery runs out.

**Mist Button:**

- 1st press: the unit sprays for 30 seconds and halts for 150 seconds with "F" indicator light on.
- 2nd press: the unit sprays for 15 seconds and halts for 165 seconds with "F" indicator light on.
- 3rd press: the unit sprays for 60 seconds and halts for 120 seconds with "F" indicator light on.

**Note:**  
Mist Button can only work under power-on status.

**Timer Button:**

- 1st press for 4h with 4h indicator light on.
- 2nd press for 8h with 8h indicator light on.
- 3rd press for 1h with 1h indicator light on.

**Note:**  
Timer Button can only work under power-on status.

**Light settings:**

- Hold for 1.5 seconds to turn on the light, light colour will automatically change and cycle through the colour options
- 2nd short press, RGB light will switch to fixed white
- 3rd short press, switch to red
- 4th short press, switch to yellow
- 5th short press, switch to green
- 6th short press, switch to warm white
- 7th short press, switch to blue
- 8th short press, switch to purple
- 9th short press, switch to pink
10. Hold for 1.5 seconds, turn off the unit

**Note:**  
Lights will reset to the default setting after turning off and on again.

100mm
100mm
100mm
100mm
100mm

110mm

**Charging the diffuser**

- Insert the USB charging cable provided into the charging port of the unit and plug into a USB power supply of DC 5V 1A or DC 5V 2A.
- Charging indicator status:  
Blinking light – battery level is less than 20%  
Breathing light – charging  
Solid light – fully charged
- Use provided USB-C Cable for charging only.
- USB power supply and essential oil not included.

**Set Up**

- Charge the diffuser's rechargeable battery using the supplied USB-C cable. Before use, refer to "charging the diffuser" section.
- Take out the handle on the circular spray cover. Pull up to remove from device.
- Use cap opener to remove the flow restrictor from the essential oil bottle.

(Note – Be careful not to spill the essential oil, as essential oils may cause damage to furniture or other surfaces. Replace flow restrictor between uses).

- Unscrew the spray cover from the empty provided bottle. Screw the spray cover directly onto your essential oil bottle.
- If your bottle does not fit into the spray cover, or the device, you may pour your essential oil into the provided empty bottle (taking care not to spill any oil) and screw this bottle back onto the spray cover.
- Taking care to keep the bottle and spray cover upright, re-insert spray cover with bottle into the diffuser, and press down.
- The diffuser is ready to use.

**Note:**  
Care should always be taken to not spill the essential oil, as essential oils may cause damage to furniture or other surfaces.

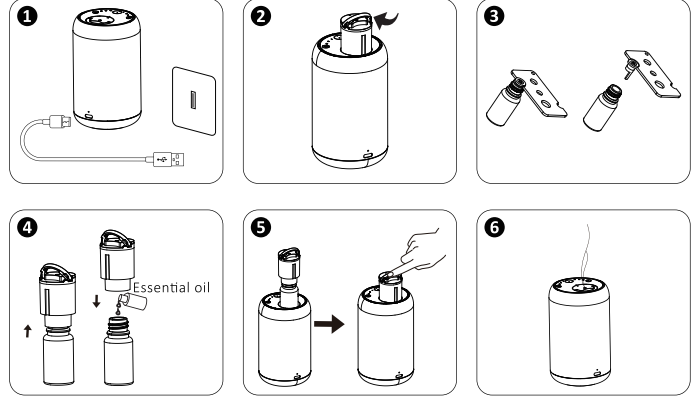

**NOTE**

Run time will vary depending on essential oil concentration and viscosity, humidity levels and other external factors. It is normal that spray may be invisible due to light or environmental factors. Essential oil use warning: Use 100% Pure Essential oil only (water soluble essential oil is not applicable). Only use the charging cable supplied with the unit. Use a soft, damp cloth to clean the diffuser. Do not disassemble or remove any parts during the product operation. Essential oil should not come in contact with the exterior surface of the unit. Essential oil is corrosive, do not let it directly come into contact with skin or splash into eyes, mouth and nose.

**Troubleshooting**

If you start up the machine but it doesn't work, please check the following diagnosis.

Problems	Possible Reasons	Handling
No electricity, not working.	Power not connected. Power wire broken or burnt out. Battery may run out if you are using the battery instead of the USB power supply.	Connect the power, press the button. Please contact local retailer.
Unable to spray mist or spray is bad.	Is the essential oil used up? Is the essential oil too sticky? Are you using a 100% pure essential oil?	Refill the oil. Change to non-sticky essential oil. Always use a 100% pure essential oil.

**12 Month Warranty**

Thank you for your purchase. Your new product is warranted to be free from defects in materials and workmanship for the period stated above, from the date of purchase, provided that the product is used in accordance with accompanying recommendations or instructions where provided. This warranty is in addition to your rights under the Australian Consumer Law. For New Zealand customers, this warranty is in addition to statutory rights observed under New Zealand legislation. We will provide you with your choice of a refund, repair (where possible) or exchange (availability dependent) for this product if it becomes defective within the warranty period. The business will bear the reasonable expense of claiming the warranty. This warranty will no longer apply where the defect is a result of alteration, accident, misuse, abuse or neglect. Please retain your receipt as proof of purchase and contact our Customer Service Centre as listed below, for the entity you purchased this product from, for any difficulties with your product. Warranty claims and claims for expense incurred in returning this product can be addressed to the respective Customer Service Centre.

Contact for Kinart purchases	Contact for Target purchases
Kinart Australia Ltd. C/- Customer Service Centre 690 Springvale Road, Mulgrave Vic 3170 Customer Service: 1800 124 125 (Australia) or 0800 945 995 (New Zealand) or via Customer Help at <a href="mailto:smart.com.au">smart.com.au</a>	Target Australia Pty Ltd C/- Customer Service Centre 2 Kendall Street, Williams Landing, Vic. 3007 Customer Service: 1300 753 567 or via Customer Help at <a href="mailto:target.com.au/help/contact-us">target.com.au/help/contact-us</a>

