

anko

**Salad Maker
HX-7830
User Manual**



**PLEASE READ AND SAVE THESE
INSTRUCTIONS FOR FUTURE REFERENCE**

IMPORTANT SAFEGUARDS

Before using the salad maker for the first time, always read the following instructions and pay attention to all warnings, even if you are familiar with handling electric devices. Store these operating instructions in a safe place for future reference. If you sell the salad maker or pass it on, always include these instructions.

1. To protect against electric shock do not immerse the appliance, power cord, plugs in water or other liquids.
2. This device must not be used by children.
3. The device and its power cable must be kept away from children.
4. Always keep plastic packaging out of reach also as it poses a suffocation risk.
5. The appliance is not intended for use by persons (including children) with reduced physical, sensory or mental capabilities, or lack of experience and knowledge, unless they have been given supervision or instructions concerning use of the appliance by a person responsible for their safety.
6. Children should be supervised to ensure that they do not play with the appliance.
7. Always handle the mains cable by the mains plug and do not pull on the cable itself.
8. Never place furniture or other heavy objects on the mains cable and take care that the cable is not kinked, especially near the mains plug.
9. Do not connect the mains cable over hot or sharp points and edges to prevent damage.
10. Do not use adapter plugs or extension cables that do not comply with applicable safety standards, and do not make any alterations to the mains cable!
11. If the supply cord or any part is damaged, it must be replaced by qualified electrician only or the product must be disposed of.
12. If smoke is produced, or there are any unusual sounds or odours, disconnect the mains cable of the electric salad maker from the socket immediately. In such cases, the electric salad maker should not be used until it has been inspected by authorized service personnel.
13. For electrical safety, only have the device repaired by qualified electrical person only. Never open the housing of the electric salad maker.
14. Be careful when using and cleaning the cones. The blades are very sharp! There is a risk of injury.
15. The salad maker must be switched off and disconnected from the mains power supply before assembling, dismantling or cleaning it.
16. When operating the device, use the supplied accessories only, particularly the pusher and cones. There is a risk of injury.
17. Be careful when operating the device; ensure that no long hair, ties or wide clothes are near the rotating parts of the salad maker as they may get caught in them. There is a risk of injury.
18. Never touch the rotating cones. There is a risk of injury.
19. Remove the mains plug from main power outlet socket each time you want to change the cone. Always wait until the cone stops rotating. There is a risk of injury.
20. Never use your bare hands to push food into the feed chute! Always use the supplied pusher. There is a risk of injury.
21. Never operate the salad maker without a cone. Never attempt to chop up fibrous foods such as meat or crush very hard foods such as ice cubes or nuts with shells. The salad maker could be damaged.
22. Always remove the mains plug from the power outlet socket after using the salad maker or when it is unattended!

23. The appliance is intended for household use only. Do not use outdoors or for commercial purpose. Any misuse will void the warranty.
24. This appliance is intended to be used indoors in household and similar application such as: staff kitchen areas in shops, offices and other working environments, farm house, by clients in hotel, motels and other residential type environments, bed and breakfast type environments.
25. For cleaning, please refer to "Cleaning" section.
26. **IMPORTANT! The maximum continuous operating time is 1 minute. Allow it to rest for at least 5 minutes before using it again.**

**SAVE THESE INSTRUCTIONS
FOR HOUSEHOLD USE ONLY**

BEFORE FIRST USE

Remove any packing material before first use. Clean the appliance and all of its accessories as described in the section "Cleaning".

CAUTION: Care should be taken when handling and cleaning the cone, cones are sharp.

1. Parts Description

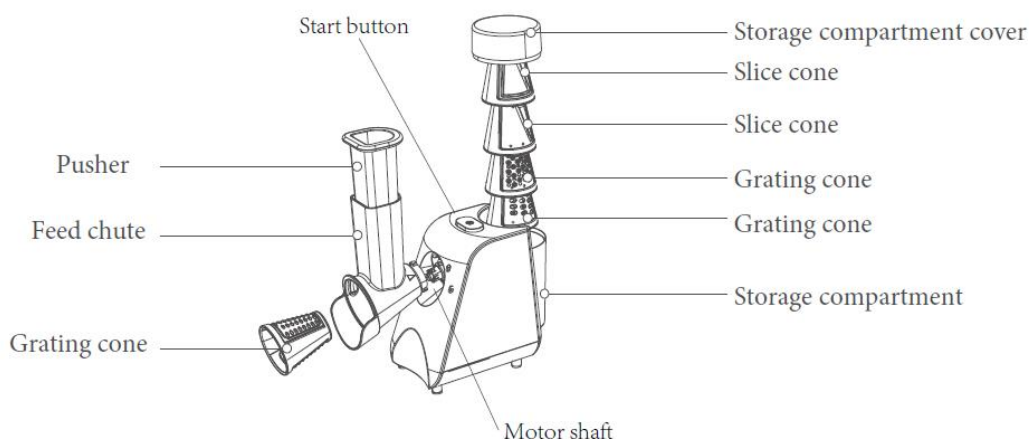

2. How to use



Be careful when removing the cones. They are very sharp! There is a risk of injury.

- 1 Place the salad maker on a level, firm surface.

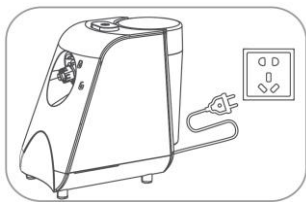

- 2 Selected the cone according to the food, push it as far as possible into the feed chute. Refer to heading 3 'Cones' to select the most suitable grating cone type.

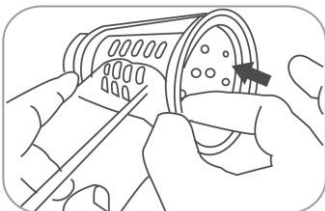

- 3 Then attach the feed chute with the inserted cone to the motor shaft so that the arrow on the feed chute points towards the open lock on the housing of the salad maker. Then rotate the feed chute anticlockwise until the arrow points to the closed lock on the housing of the salad maker. A "click" sound indicates the feed chute is installed properly.

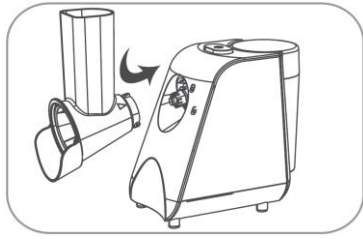

- 4 Place a suitable bowl under the opening of the cone to collect the processed food.

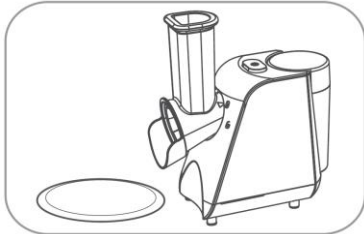

- 5 Now plug in the socket and insert the prepared food in the feed chute.
- 6 Press the Start button and keep it pressed. The cone in use then rotates.

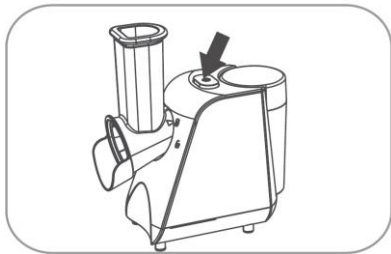

- 7 The food in the feed chute can be inserted into the cone using the pusher. When the feed chute is empty, you can insert more food if necessary.
The processed food falls forwards from the opening of the cone to the bowl placed previously under the device.

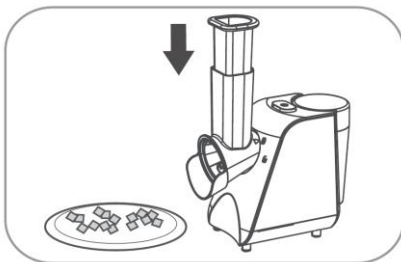

- 8 After all prepared foods have been processed; release the Start button.
- 9 If you want to process larger quantities of food, always observe the short operating time of 1minutes to avoid damaging the salad maker.
- 10 Remove the mains plug from the socket.
- 11 To remove the cone, proceed as follows:
Unplug the salad maker. Then rotate the feed chute clockwise until the arrow points to the open lock on the housing of the salad maker.
Use the thumb and index finger to grip the edge of the inserted cone and feed chute and press them together as shown in the illustration.

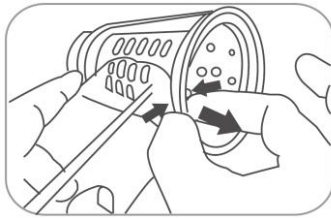







Be careful when removing the cones. The blades are very sharp! There is a risk of injury.

Please note that you cannot insert or remove the cone while the feed chute is attached to the salad maker.

3. Cones

For the range of applications of the various cones, please refer to the following diagram:

SLICE	 Yellow/Green cones	
	 Red/Orange cones	
GRATE	 Blue cone	

The following table should assist you in selecting the appropriate cone for selected foods:

Food	Yellow/Green cone	Red/ Orange cone	Blue cone
Apple	■		
Cucumber	■		
Hard cheese		■	■
Hazelnuts, almonds			■
Potatoes	■	■	
Coconut			■
Carrots	■	■	
Capsicum	■	■	
Parmesan			■
Radishes	■	■	
Beetroot	■		
Red or white cabbage	■		
Chocolate		■	■
Dry bread			■
Zucchini	■	■	
Onions, shallots	■		

4. Mains cable/ mains cable duct

Now, pull the integrated mains cable as required from the mains cable duct and insert the mains plug into a socket that is always easily accessible. You can store the mains cable again in the mains cable duct after use.



5. Cleaning

WARNING! Always remove the mains plug from the socket before cleaning. Never immerse the salad maker in water and never clean it under running water. There is a risk of an electric shock!

WARNING! Be careful when using and cleaning the cones. The blades are very sharp. There is a risk of injury!

Do not use any aggressive, abrasive or chemical cleaning agents. The surface of the salad maker and the accessories could be damaged.

- Clean the salad maker with a damp cloth. You can apply a mild detergent to the cloth to remove stubborn dirt. Ensure that you remove all remaining detergent with a wet cloth.
- The 5 cones, the storage compartment, the storage compartment cover, the feed chute, and the pusher are suitable for cleaning in a dishwasher.

Please note that some foods, for example, carrots or red cabbage, contain natural dyes. The plastic parts of the salad maker and the accessories may be discolored by these dyes. This is normal and not a defect of the product.

6. Storage

If the salad maker is not used for a prolonged period, store it in a dry and clean location.

- Clean the salad maker and all accessories as described in the previous section.
- Store the 5 cones in the storage compartment.
- Insert the mains cable so far into the mains cable duct that only the mains plug can be seen.

7. Technical Specification

Voltage : 220-240V~ 50-60Hz

Power : 50W

12 MONTH WARRANTY

Thank you for your purchase from Kmart.

Kmart Australia Ltd warrants your new product to be free from defects in materials and workmanship for the period stated above, from the date of purchase, provided that the product is used in accordance with accompanying recommendations or instructions where provided. This warranty is in addition to your rights under the Australian Consumer Law.

Kmart will provide you with your choice of a refund, repair or exchange (where possible) for this product if it becomes defective within the warranty period. Kmart will bear the reasonable expense of claiming the warranty. This warranty will no longer apply where the defect is a result of alteration, accident, misuse, abuse or neglect.

Please retain your receipt as proof of purchase and contact our Customer Service Centre on 1800 124 125 (Australia) or 0800 945 995 (New Zealand) or alternatively, via Customer Help at Kmart.com.au for any difficulties with your product. Warranty claims and claims for expense incurred in returning this product can be addressed to our Customer Service Centre at 690 Springvale Rd, Mulgrave Vic 3170.

Our goods come with guarantees that cannot be excluded under the Australian Consumer Law. You are entitled to a replacement or refund for a major failure and compensation for any other reasonably foreseeable loss or damage. You are also entitled to have the goods repaired or replaced if the goods fail to be of acceptable quality and the failure does not amount to a major failure.

For New Zealand customers, this warranty is in addition to statutory rights observed under New Zealand legislation.