

Multi Weight Stand

Key Code: 43057290

Thank you for purchasing the sturdy and compact Multi Weight Stand. This product is designed to keep your workout area organized and to provide easy access to your weights.

Product

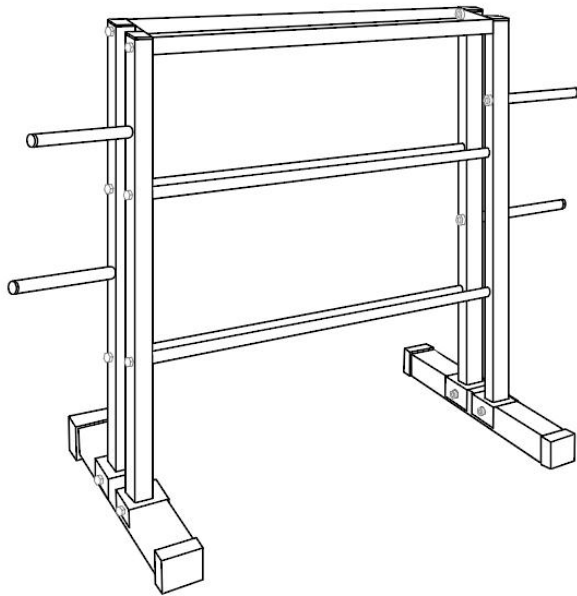

Hardware List



Bolt M8x65mm
A x4pc

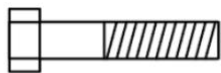

Bolt M10x40mm
B x4pc

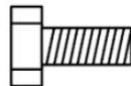

Bolt M12x16mm
C x8pc



Nut M8
D x4pc



Nut M10
E x4pc



Washer M12
F x4pc



Washer M10
G x4pc



Washer M8
H x4pc

Part List



Left stand tube
I x2pc

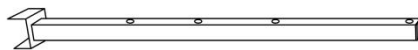

Right stand tube
J x2pc

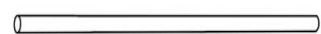

Cross bar tube
K x4pc

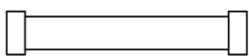

Base tube
L x2pc



Top frame
M x1pc

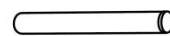

Weight bar
N x4pc

Assembly Instructions

Note: To assemble easily and successfully, please keep the bolts 70% of tightness while installing the parts, then fasten all the bolts and nuts fully after finished assembly.

Step 1. Connect 2pcs left stand tube (Part I) and cross bar tube (Part K) together, then secure them with bolts (Hardware C). Connect 2pcs right stand tube (Part J) and cross bar tube (Part K) together, then secure them with bolts (Hardware C).

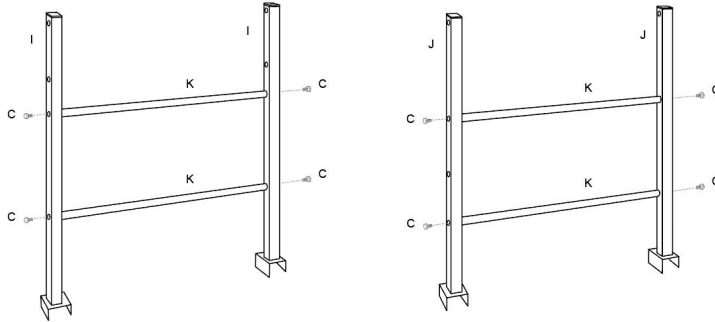

Step 2. Connect the 2pcs parts of step 1 and the base tube (Part L) together, then secure them with bolts, nut and washer (Hardware A,D,H).

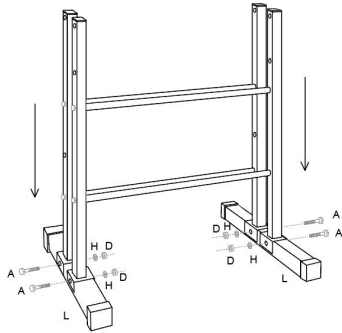

Step 3. Connect the part of step2 and top frame (Part M) together, then secure them with bolt, nut and washer (Hardware B,E,G).

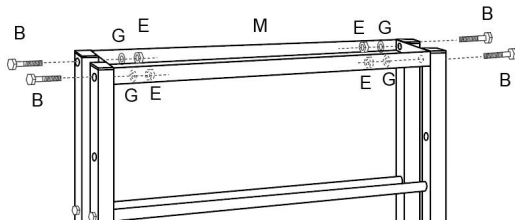

Step 4. Insert the 4pcs weight bars (Part N) into the hole of stand tubes, then secure them with bolt and washer (Hardware C,F).

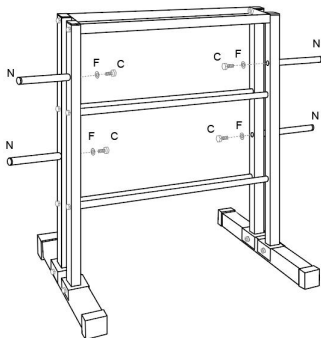

WARNING:

1. The product must be placed on a hard, flat surface, cover the floor with carpet to prevent damage to the ground.
2. Check the parts and tighten all bolts and nuts regularly, never use the product if all components are **NOT** fully secure.
3. Always keep children away from the product unless they are supervised by an adult.
4. Wipe clean with damp cloth. Do not use abrasive materials or solvents.
5. Always store the product on a flat surface, and in a dry and well ventilated area.

FOR AU/NZ: IMPORTED FOR K MART STORES IN AUSTRALIA AND NEW ZEALAND.

Made in China