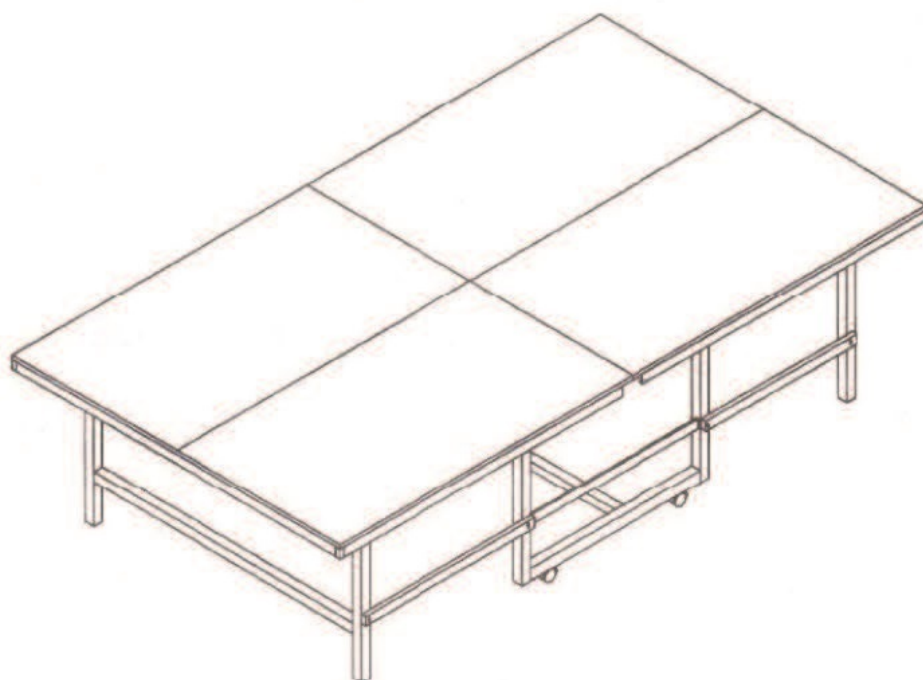

TABLE TENNIS TABLE ASSEMBLY & INSTRUCTION MANUAL

KEYCODE: 42691044



⚠ WARNING

DO NOT ASSEMBLE OR USE THIS TABLE WITHOUT READING THIS MANUAL.
THIS TABLE IS FOR HOME RECREATIONAL USE ONLY, NOT FOR COMMERCIAL USE.
NOT SUITABLE FOR CHILDREN UNDER 6 YEARS OF AGE.
ADULT SUPERVISION IS REQUIRED WHEN CHILDREN ARE PLAYING.

INSTRUCTION MANUAL

CAUTION

THIS IS A GAME TABLE . DO NOT SIT , STAND , LEAN , WALK OR JUMP ON TABLE . FAILURE TO COMPLY WITH THIS CAUTION COULD RESULT IN PERSONAL INJURY AND PROPERTY DAMAGE !

THIS TABLE MUST BE KEPT INDOORS TO PREVENT DAMAGE TO THE PLAYING SURFACE . DAMPNES AND EXTREME TEMPERATURE CHANGES WHICH OCCUR ON PATIOS , GARAGES OR SIMILAR AREAS CAN CAUSE WOOD TO WARP , SWELL , CRACK OR BLISTER .

UNLEVEL FLOORS :

IF TABLE DOES NOT SEEM LEVEL , IT IS PROBABLY BECAUSE FLOOR IS NOT LEVEL . MOVE TABLE SEVERAL INCHES (SET TABLE IN PLAYING POSITION) IN DIFFERENT DIRECTIONS TO FIND THE BEST LOCATION FOR THE TABLE . IF THE FLOOR IS EXTREMELY UNLEVEL . TABLE MAY NOT PLAY OR OPERATE PROPERLY . IF TABLE IS HIGH IN THE CENTER SHIM UP UNDER THE OUTER LEGS , OR ADJUST THE HEIGHT OF THE FOUR LEG WHEEL .

CARE AND MAINTENANCE :

THE PLAYING SURFACE OF THE TABLE CAN BE AFFECTED BY ATMOSPHERIC CONDITIONS , MEANING BOTH TEMPERATURE AND HUMIDITY . THIS MAY CAUSE A SLIGHT SAG OR DISTORTION AS TOP EXPANDS OR CONTRACTS . THIS IS NORMAL AND SHOULD NOT CAUSE CONCERN AS IT DOES NOT DETRACT FROM THE PLAY OR UTILITY VALUE OF THE TABLE . TO HELP MINIMIZE THIS PROBLEM , STORE TABLE IN THE FOLDED UP POSITION IN A DRY AREA WHEN NOT IN USE .

STORAGE OF YOUR TABLE :

THIS TABLE MUST BE STORED INDOORS TO PREVENT DAMAGE TO THE PLAYING SURFACE . DAMPNES AND EXTREME TEMPERATURE CHANGES WHICH OCCUR ON PATIOS , GARAGES OR SIMILAR AREAS CAN CAUSE THE WOOD TO WARP , SWELL , CRACK , OR BLISTER . WHEN YOUR TABLE IS NOT IN USE , IT SHOULD BE FOLDED UP AND STORED IN A DRY AREA .

CLEANING YOUR TABLE :

TO CLEAN YOUR TABLE USE A SOFT DAMP NOT WET CLOTH ONLY . TO PREVENT DAMAGE TO YOUR TABLE'S PLAYING SURFACE DO NOT USE ANY CHEMICALS , ABRASIVE , OR CLEANING PRODUCTS ON YOUR TABLE'S PLAYING SURFACE . IMPORTANT : PERIODICALLY , LUBRICATE ALL MOVING PARTS , INCLUDING PIVOT POINTS , TO ENSURE SMOOTH OPENING AND CLOSING . A LIGHT LUBRICANT SUCH AS WS-40 IS RECOMMENDED .

TOOLS REQUIRED:

Phillips Screwdriver - **Not Included**

Standard (Flat Head Screwdriver) - **Not Included**

Allen Wrench - **Not Included**

CAUTION ! Electric Screwdrivers may be helpful during assembly; however, please set a low torque and use extreme caution.

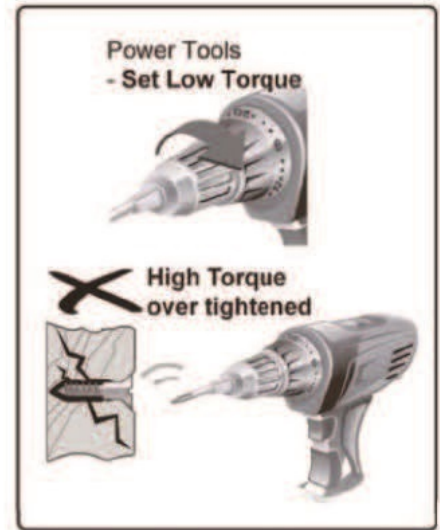

ASSEMBLY TIPS:

- 1 - Please read the instructions carefully, and follow all assembly, operation or safety instructions properly in order to avoid damage or injury. For the assembly, at least two adults are required.
- 2 - Some figures or drawings may not look exactly like your product. Please read and understand the text before beginning each assembly step.

IMPORTANT NOTICE!

- 1 - This product is intended for INDOOR use only.
- 2 - Please Do Not sit, climb or lean on the game table.
- 3 - Please Do Not drag the table when moving it in order to avoid damage to the legs.
- 4 - Please only use spray furniture polish to clean the exterior surfaces on the game table.
- 5 - This is not a child's toy, adult supervision is required for children playing this game.

CAUTION !

Changes or modifications not expressly approved by the party responsible for compliance could void the user's authority to operate the equipment.



WARNING: Adult Assembly Required.



Strong Adults Needed



No Children in
Assembly Area













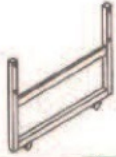



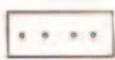

Keep away from pets













Do not use or keep product
outdoors. For indoor use only.
No wet/humid conditions.

PART LIST

	P41	TABLE TOP	2PCS
	P42	TABLE TOP	2PCS
	P1A	"U" LEG TUBE	1PC
	P1B	"U" LEG TUBE	1PC
	P3A	CONNECTION TUBE	2PCS
	P3B	CONNECTION TUBE	2PCS
	P3C	SQUARE TUBE	1PC
	P4A	"H" LEG TUBE	2PCS
	P4B	TABLE TOP SUPPORT TUBE	4PCS
	P5	TABLE TOP CONNECTION PLATE	4PCS
	P4C	TABLE TOP SUPPORT TUBE (pre-assembled)	4PCS
	P4D	PLASTIC CORNER	8PCS
	P4D1	25*25MM END CUP (pre-assembled)	16PCS
	P4D2	10*20MM END CUP (pre-assembled)	8PCS

	P4E	SUPPORT TUBE BRACKET (pre-assembled)	16PCS
	H9-N	LEG WHEEL	4PCS
	H10	TIE STRAP	1SET
	H11	ADJUSTABLE SCREW	4PCS

HARDWARE LIST

	H1	BOLT 6×65MM	8PCS
	H2	BUSHING	8PCS
	H3	BUSHING	8PCS
	H4	LOCKING NUT (M6)	16PCS
	H5	BOLT 6×45MM	8PCS
	H6	LOCKPIN	2PCS
	H8	SCREW M3×29MM (28pcs pre-assembled)	60PCS
	H12	BOLT 6×50MM	2PCS
	H7	SCREW 4×10MM	18PCS
	H13	WASHER	2PCS
	H7A	SCREW 4×12MM (pre-assembled)	64PCS

ASSEMBLY INSTRUCTION

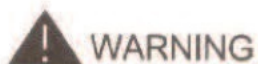

WARNING

- (1) READ AND FOLLOW ALL ASSEMBLY , OPERATING , AND SAFETY INSTRUCTIONS CAREFULLY .
- (2) IT WILL MAKE THE ASSEMBLY EASIER AND FASTER IF THE THIRD PERSON IS AVAILABLE TO HELP YOU .

STEP1

Place four table top P4 of the table tennis table face down on a clean , flat surface . See figure 1 . Remove all parts from the box and match up to the parts diagram .

DO NOT STEP ON AND DO NOT WALK ON THE 4 TABLE TOP PIECES DURING THE ASSEMBLY PROCESS .

Note : Do not leave any space or gap between the 4 table top panels . Make sure all edges are tight up against each other . As shown in figure 1 .

ATTENTION: assemble the end cap (P4D) with table top support tube (P4C) first, then go to the next step.

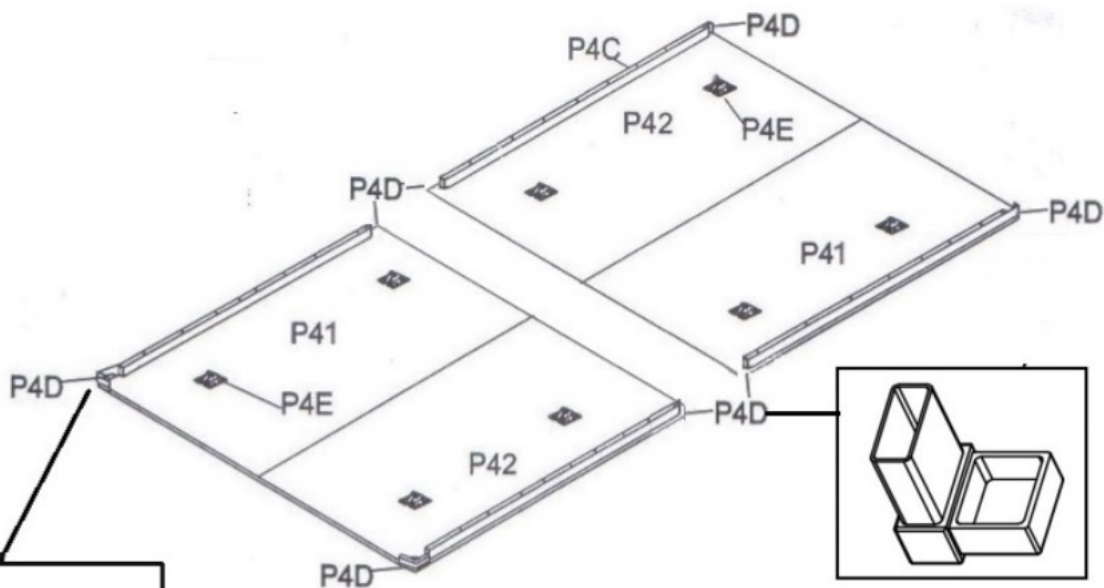
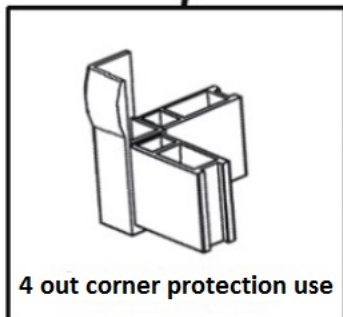

FIGURE 1



STEP2

Attach two table top support tubes P4B on two ends of table tops P4 with screw H8 . See figure 2 .

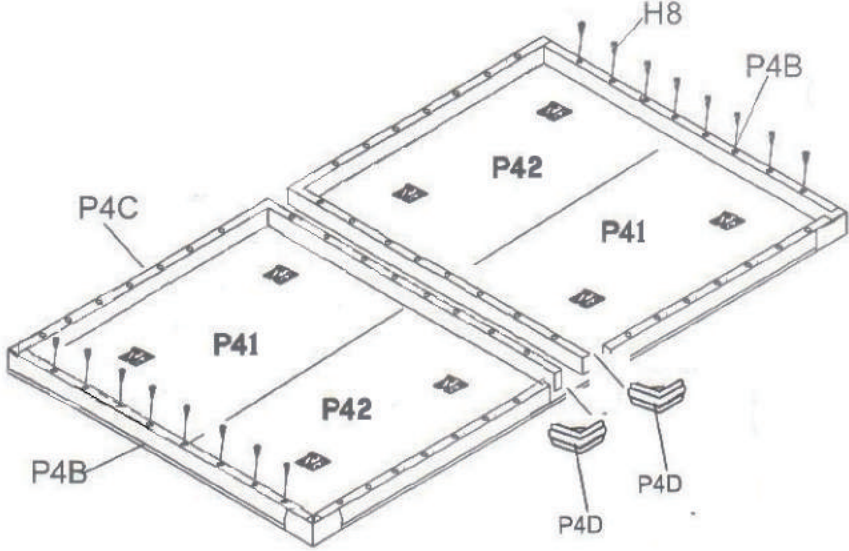

FIGURE 2

STEP3

Attach another two table top support tube P4B on the two sides of the midline with screw H8 . See figure 3 . Note : Two table top support tubes P4B must connect with table top support tube P4C pre-assembled upright .

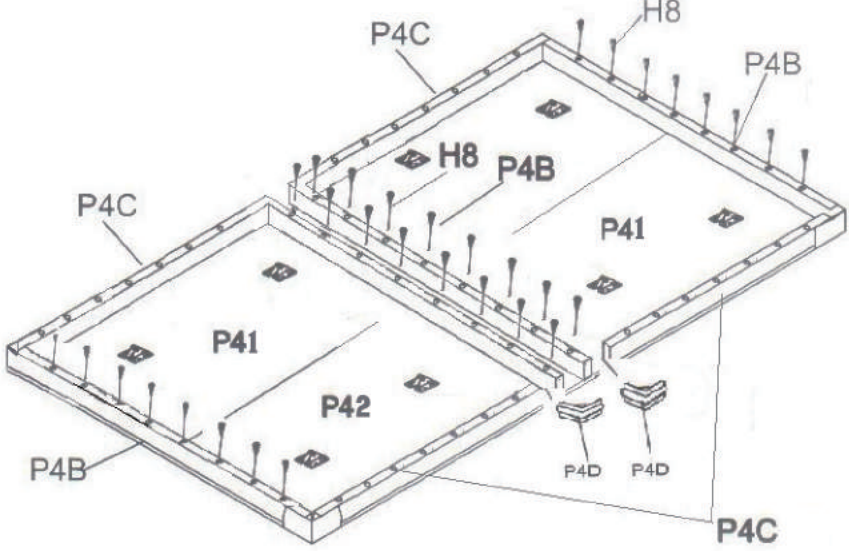

FIGURE 3

STEP4

Attach table top connection plate P5 on the transverse midline of each two table top P4 with screw H7 . See figure 4 .

Note : Be sure to put the table top connection plate P5 on average position of the midline .

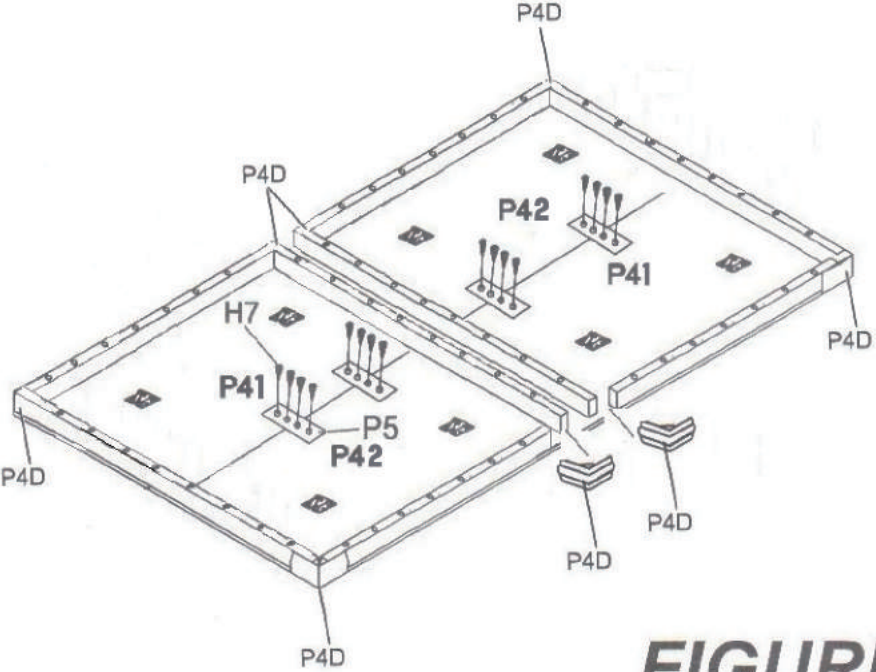

FIGURE 4

STEP5

Attach H leg tube P4A and support tube bracket P4E with bolt H5 , nut H4 . See figure 5 .

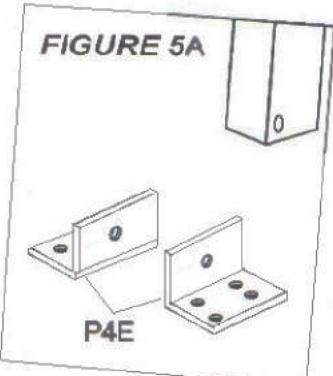
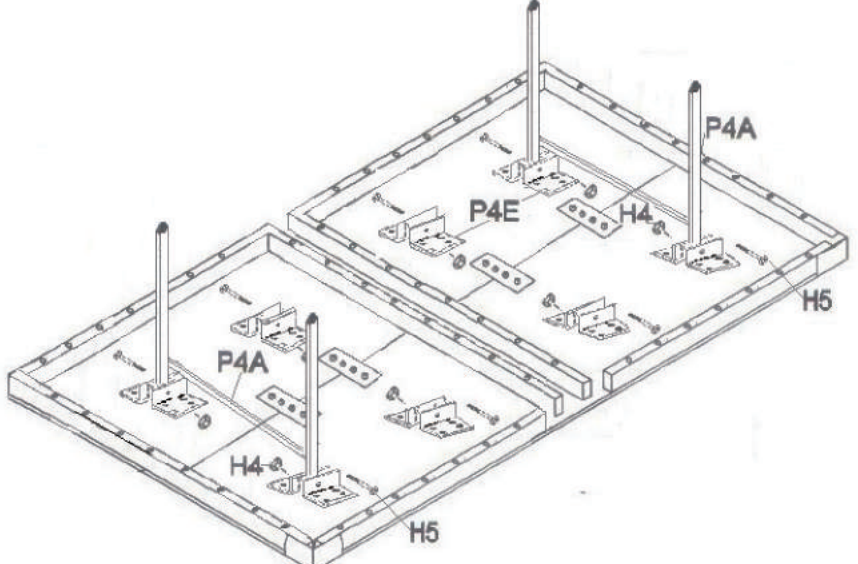

FIGURE 5

STEP6

Connect the square tube P3C to U leg tube P1A and P1B with bolt H12 , turn both U legs in upright position . See figure 6 .

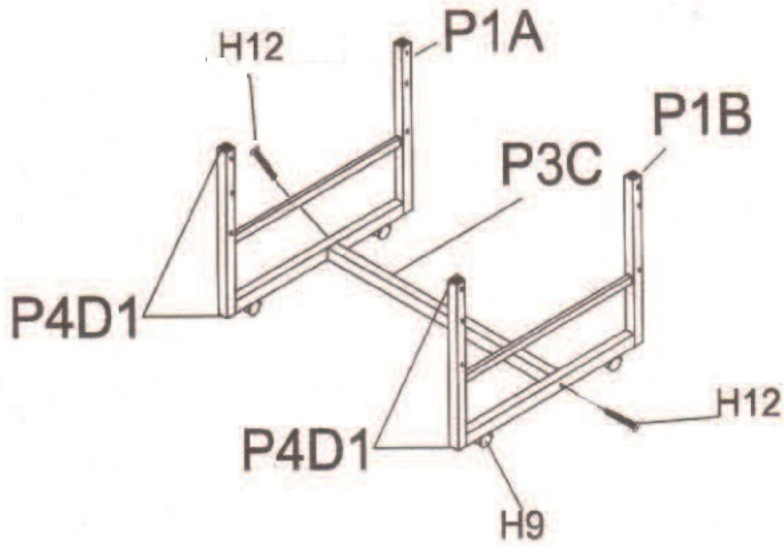

FIGURE 6



WARNING

TABLE TOPS ARE HEAVY , DO NOT ATTEMPT TO ASSEMBLE ALONE .

STEP 7

Put 2 pieces of table top P4 on the upper of the U leg . Be sure to have the table leg (P4A) in steady position when assembly . Please have one adult help you to hold another side of two U leg until you have finished the step 7 . See figure 7 .

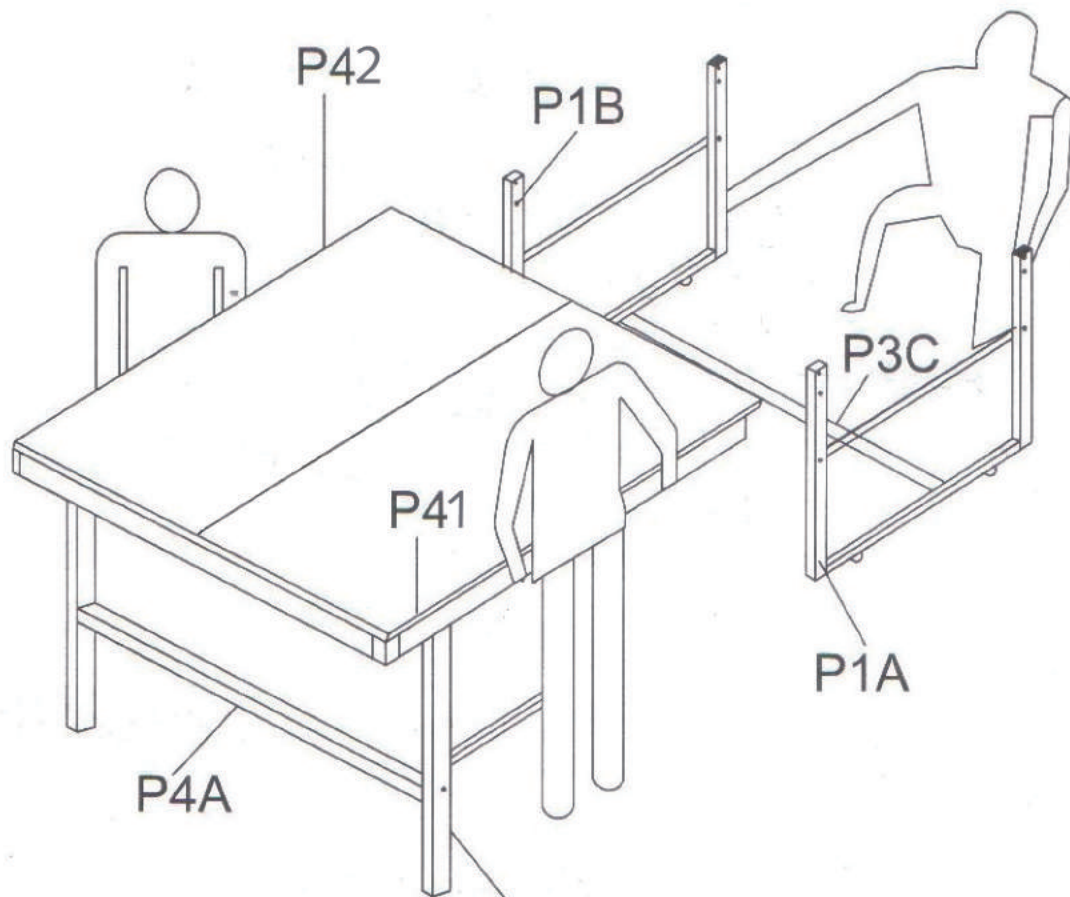

! WARNING
PLEASE MAKE SURE THESE
P4A LEGS ARE IN A 90°
STEADY POSITION

FIGURE 7

STEP8

Attach the end of U leg tube underneath the table to the support tube bracket (P4E) with bolt H5 , and nut H4 . See figure 8 ; Repeat same assembling process for the other end of U leg .



NOTE :

ASSEMBLY PICTURE SHOWN BELOW IS PARTIALLY UNDERNEATH THE TABLE TOP

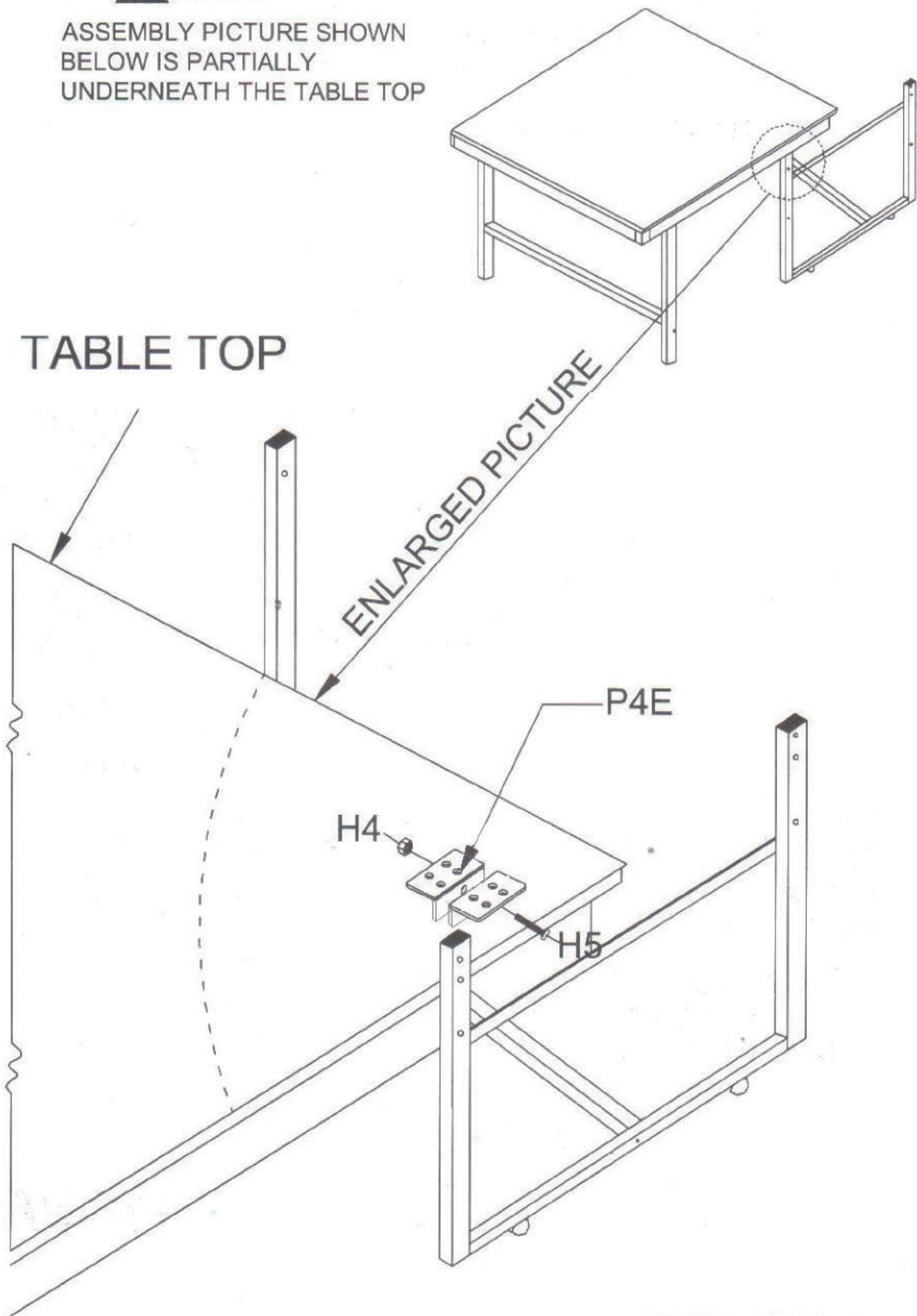

FIGURE 8

STEP9

Attach the flat connection tube P3A with the hole away from the end to the upright leg(P4A) with bolt H1 and bushingH3 、 bushing H2 , and nut H4 , as shown in the figure 9 .

Repeat same assembling process for the other end of tube .

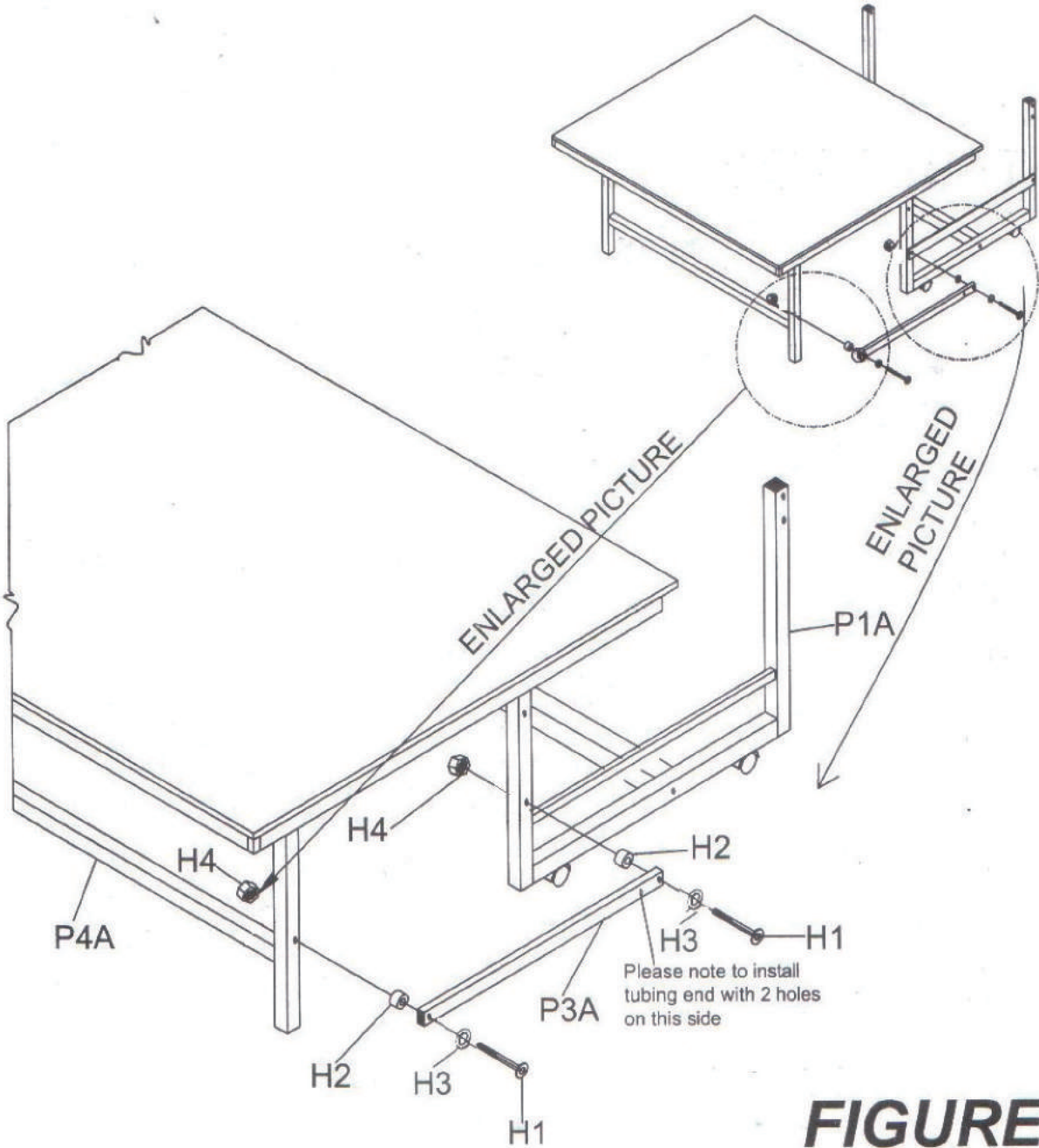
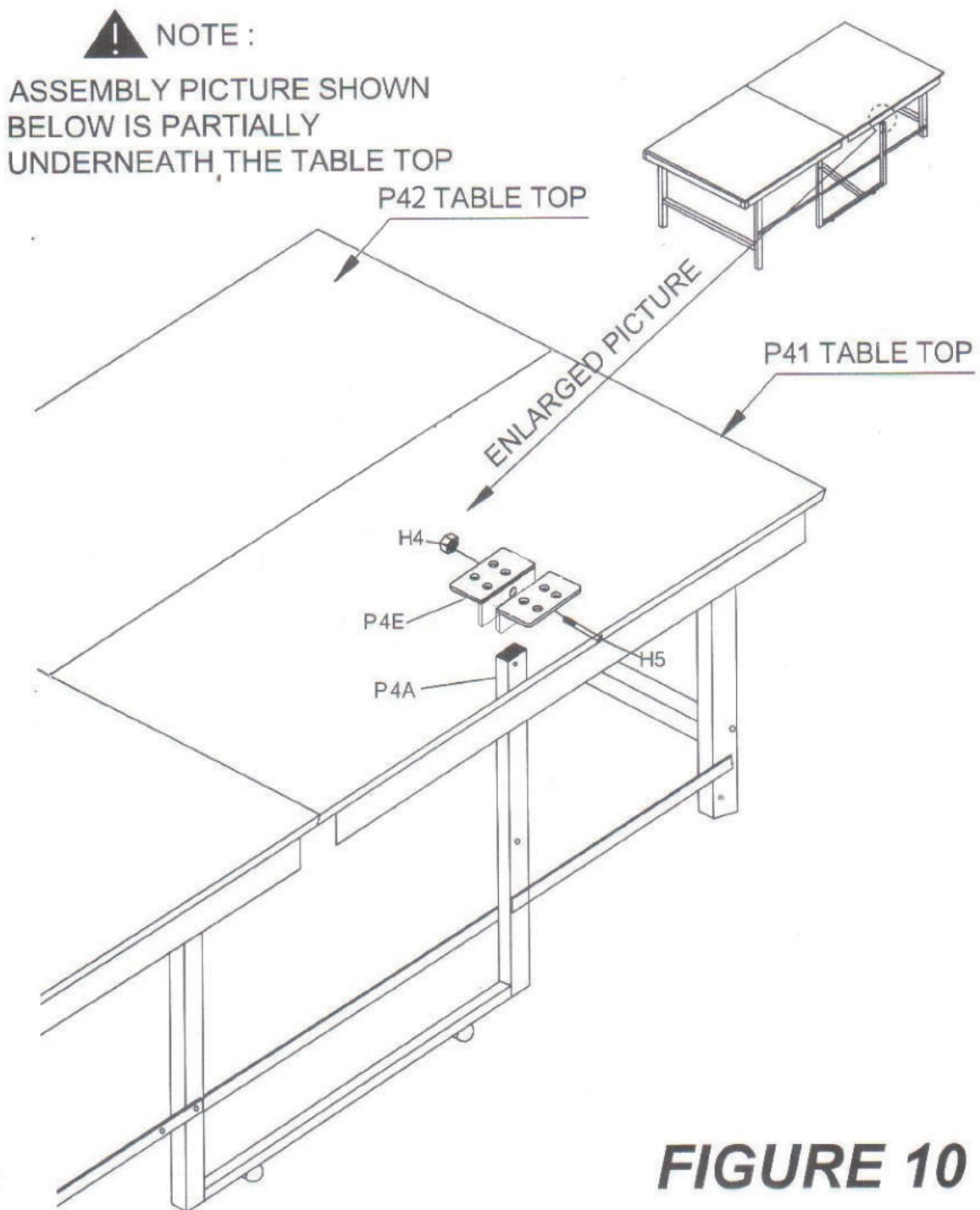

FIGURE 9

- STEP10** Put another 2pcs of table top P4 on the other side of upper of U leg .
(Note : Be sure to have leg in steady position) , see figure 10 ;
- STEP11** Attach the end of U leg tube underneath the table to tube bracket P4E with bolt H5 , nut H4 . see figure 10 ;
Repeat same assembling process for the other end of leg .



STEP12

Attach the flat connection tube P3A with the hole away from the end to the upright leg tube P4A with bolt H1 , bushing H3 , bushing H2 and nut H4.see figure 11 ;

Repeat same assembling process for the other end of tube .

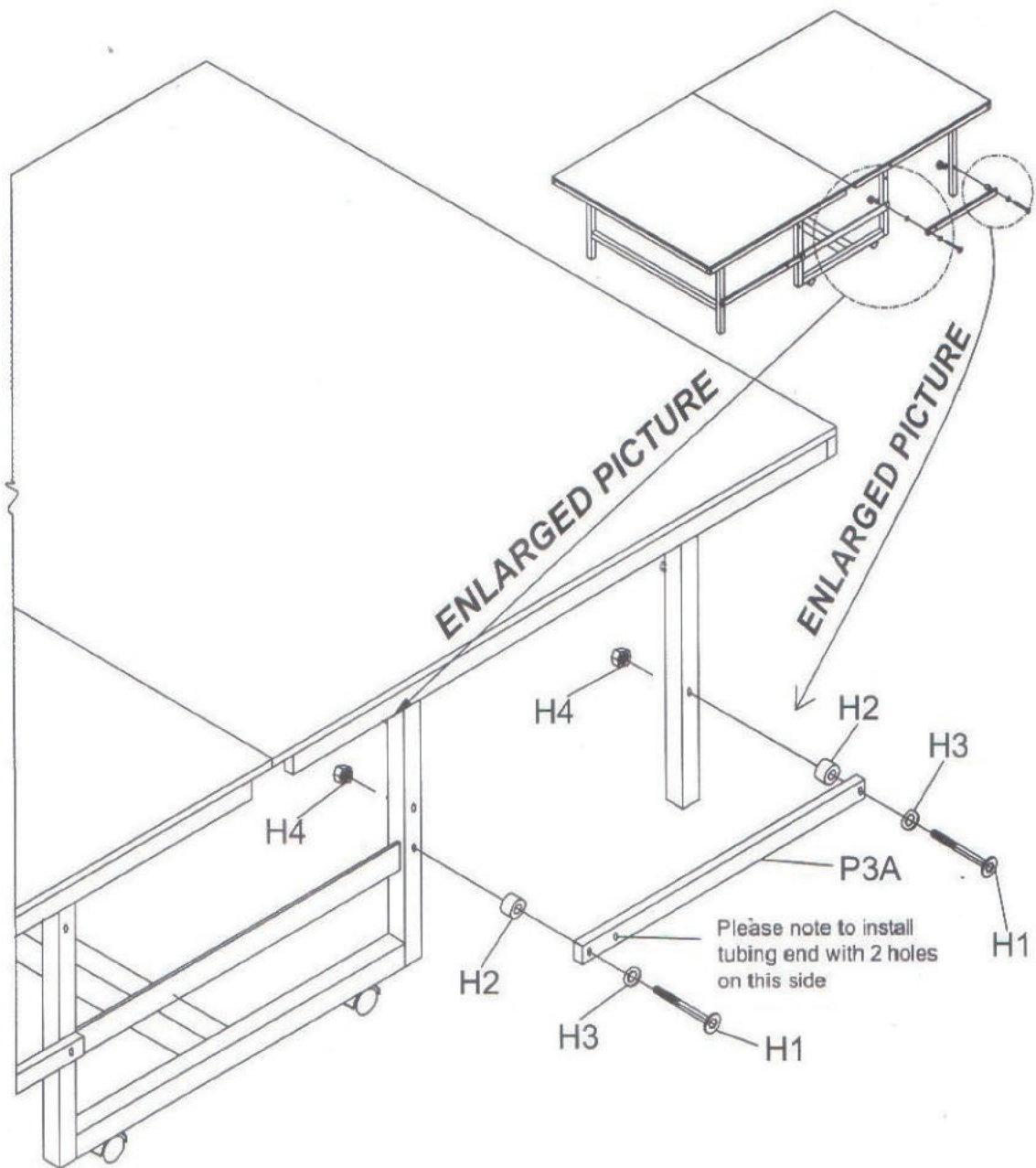
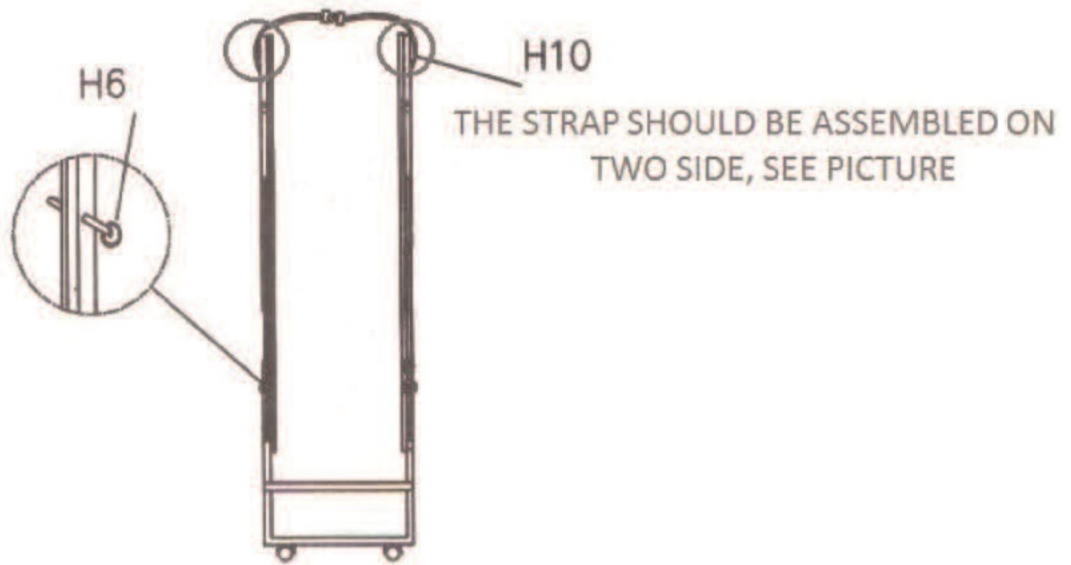
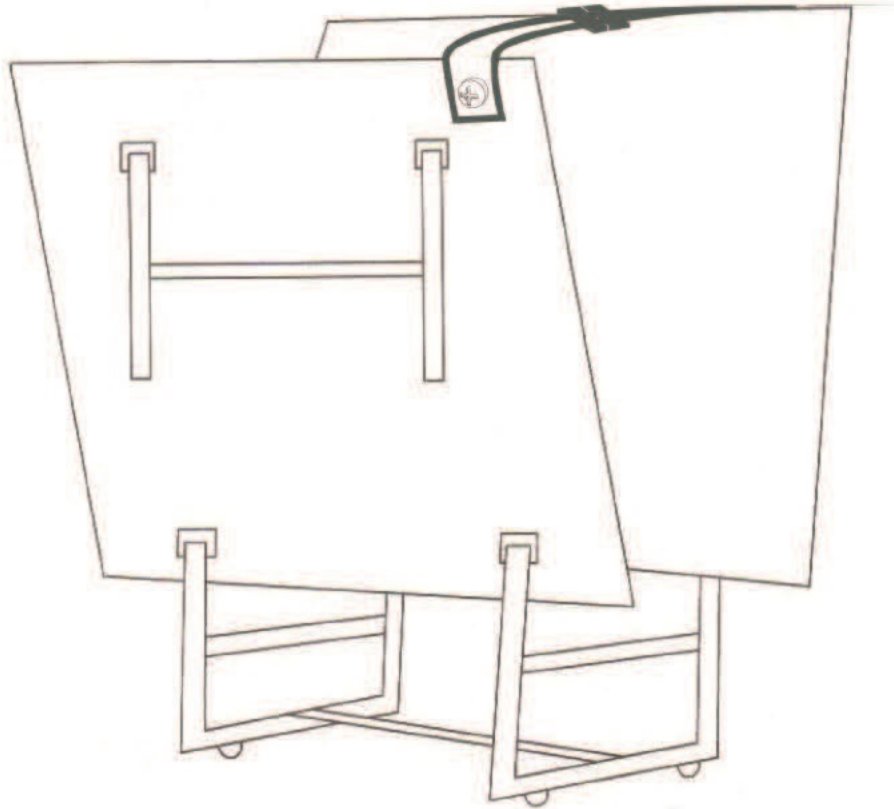

FIGURE 11

STEP 13

assemble tie strap (H10) on board by H7 screw and H13 washer.



OPENING AND CLOSING INSTRUCTIONS

CAUTION

EXERCISE CAUTION IN OPENING/CLOSING TABLE . SMALL CHILDREN MUST NOT BE ALLOWED TO OPEN/CLOSE TABLE . IMPROPER HANDLING AND MISUSE CAN RESULT IN SERIOUS INJURY OR DAMAGE . DO NOT CLIMB , STAND , OR JUMP ON TABLE . MOISTURE AND CONDENSATION WILL DAMAGE PLAYING SURFACE OF THIS TABLE . STORE IN DRY , INDOOR PLACE . .

TO CLOSE :

1. REMOVE NET AND NET POSTS FROM TABLE ; (NOT INCLUDED)
2. LIFT TABLE HALF WITHOUT NET POSTS TO MIDPOINT . THEN CONTINUE LIFTING UNTIL CLOSED ;
3. INSERT LOCKPIN INTO HOLE OF LEG CONNECTION TUBE AND U LEG TUBE ; BE SURE TO HAVE THE STEEL BALL ON LOCKPIN GO THROUGH THE TWO TUBES ;
4. RAISE OTHER TABLE HALF IN THE SAME MANNER ;

D

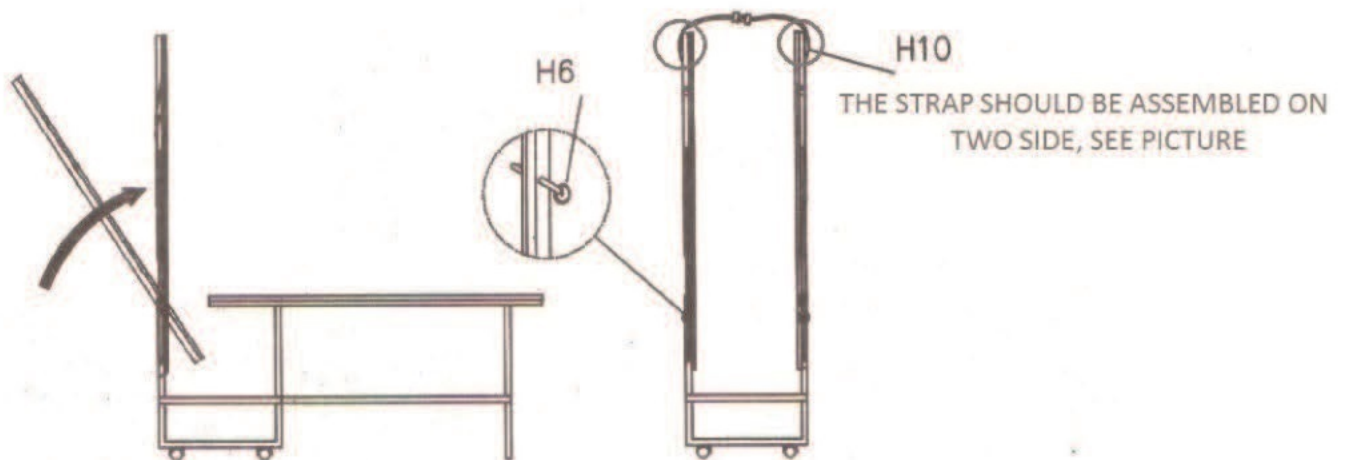

MOVING:

1. BE SURE TO HAVE THE LOCKPIN INSERTED INTO HOLE OF TWO LEG TUBES , AND BUTTON UP THE TIE STRAP ;
2. RELEASE THE BRAKE OF LEG WHEELS ;
3. HAVE ONE ADULT ON EACH END OF TABLE , PUSH THE TABLE IN THE SAME DIRECTION .

⚠ WARNING : MOVING THE TABLE WITHOUT RELEASING THE BRAKE ON WHEELS WILL DAMAGE THE WHEELS .

TO OPEN:

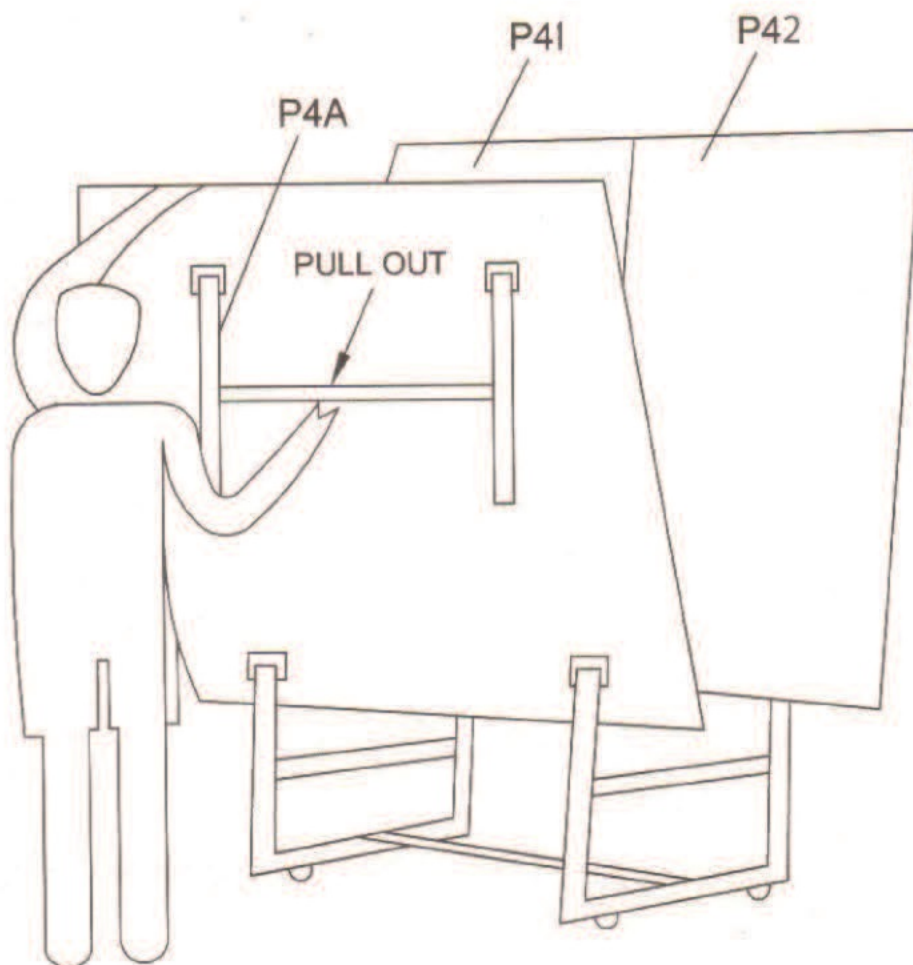

TO OPEN:

- (1) RELEASE THE TIE STRAP AND REMOVE THE LOCKPIN ; WHILE HOLDING THE TOP EDGE OF THE TABLE AS SHOWN .
- (2) PULL THE LEG FRAME OUT BY HOLDING THE CROSS BAR AS SHOWN . SLOWLY ALLOW THE TABLE TOP TO ROTATE DOWNWARD UNTIL LEG FRAME RESTS PROPERLY ON THE FLOOR .

12 Month Warranty

Thank you for your purchase from Kmart.

Kmart Australia Ltd warrants your new product to be free from defects in materials and workmanship for the period stated above, from the date of purchase, provided that the product is used in accordance with accompanying recommendations or instructions where provided. This warranty is in addition to your rights under the Australian Consumer Law.

Kmart will provide you with your choice of a refund, repair or exchange (where possible) for this product if it becomes defective within the warranty period. Kmart will bear the reasonable expense of claiming the warranty. This warranty will no longer apply where the defect is a result of alteration, accident, misuse, abuse or neglect.

Please retain your receipt as proof of purchase and contact our Customer Service Centre on 1800 124 125 (Australia) or 0800 945 995 (New Zealand) or alternatively, via Customer Help at Kmart.com.au for any difficulties with your product. Warranty claims and claims for expense incurred in returning this product can be addressed to our Customer Service Centre at 690 Springvale Rd, Mulgrave Vic 3170.

Our goods come with guarantees that cannot be excluded under the Australian Consumer Law. You are entitled to a replacement or refund for a major failure and compensation for any other reasonably foreseeable loss or damage. You are also entitled to have the goods repaired or replaced if the goods fail to be of acceptable quality and the failure does not amount to a major failure.

For New Zealand customers, this warranty is in addition to statutory rights observed under New Zealand legislation.